



SPECIFICATION
OF
MITSUBISHI DIESEL ENGINE
MODEL : S16R-PTA
(WITH FAN)
FOR DIESEL GENERATOR SET
EMERGENCY APPLICATION

Used for 1650kVA generator

THE INFORMATION HEREON IS THE PROPERTY OF MITSUBISHI HEAVY INDUSTRIES, LTD.
WITHOUT WRITTEN PERMISSION, ANY COPYING, TRANSMITTAL TO OTHERS, AND ANY USE EXCEPT
THAT FOR WHICH IT IS LOANED, IS PROHIBITED.

MITSUBISHI HEAVY INDUSTRIES, LTD

							APPROVED BY	CHECKED BY	DRAWN BY
							橋口	岸	坂本
				△					
				DATE	2016/4/1				

1. DRAWINGS

NO.	DWG. NO.	DWG. NAME	REV.
1	38F96-00251	ENGINE OUTLINE	
2	37896-01008	JOINT DETAIL	
3	38E96-04051	WIRING DIAGRAM	
4	37896-14001	MOUNTING DETAIL	
5	37896-21001	FLYWHEEL & HOUSING DETAIL	
6	38F96-30351	AIR CLEANER	
7	37896-43013	BREATHER	
8	37896-61312	FUEL RETURN PIPING	
9	37896-62112	FUEL INLET PIPING	
10	37896-63005	GOVERNOR	
11	38E96-66051	STARTING MOTOR	
12	38E96-68051	DYNAMO	
13	37896-71001	TURNING GEAR	
14	37896-87502	STOP SYSTEM	
15	38F96-90152	METER & SENSOR	
16	37896-90207	ALARM SWITCH	
17	S35-5030	AIR CLEANER ASSY	
18	S35-5110	BAND	
19	S35-5230	CAP	
20	S11-0920	INDICATOR	
21	S11-0551	THERMO SWITCH	
22	S11-0796	PRESSURE SWITCH	
23	S11-1371	FILTER ALARM SWITCH	
24	S13-0282	SOLENOID	
25	S13-1022	CONNECTOR	
26	S13-1042	CONTROLLER,SPEED	
27	S13-1761	ACTUATOR	
28	S13-2011	MAGNETIC PICK UP	
29	S13-2020	CABLE, PICK UP	
30	S14-0330	CONNECTOR	
31	S37-1090	FLEXIBLE PIPE	
32	S35-0720	ELBOW/45°	

NO.	DWG. NO.	DWG. NAME	REV.
33	S35-0701	HOSE,RUBBER	
34	S35-0711	HOSE,RUBBER	

2. TECHNICAL INFORMATION

NO.	DWG. NO.	DWG. NAME	REV.
35	T0233-0001E	SPECIFICATION SHEETS	

MHI CONFIDENTIAL

3. GENERAL

Object and use	:	Diesel generator
Color of painting	:	7.5BG6/1.5
Applicable conditions		
Ambient temperature	:	5°C ~ 40°C
Altitude	:	1500m above sea level
Max ,humidity	:	85%
Place of installation	:	In door

Shop test

Diesel engine running tests shall be carried out by the following items.

Starting test

Load test	:	1/4, 2/4, 3/4 Load each
	:	4/4 Load

Governor test	:	Governor test should be done along with respective governor controller
---------------	---	---

Safety stop device test

Standard

All items, unless otherwise specified, are in accordance with JIS, and manufacturer's standards.

4. PRINCIPAL PARTICULARS

Model	:	S16R-PTA
Type	:	4cycle stroke, water cooled diesel engine
Combustion chamber	:	Direct injection type
Aspiration	:	Turbocharged with after cooler
Number of cylinders	:	16-V
Bore × stroke	:	170mm × 180mm
Total displacement	:	65.37liter
Compression ratio	:	14.0 : 1
firing order	:	1 - 9 - 6 - 14 - 2 - 10 - 4 - 12 - 8 - 16 - 3 - 11 - 7 - 15 - 5 - 13
Direction of rotation	:	Counter clockwise as viewed from flywheel side
Engine dimensions (Approx.)	:	Length Apx. 3223mm
	:	width Apx. 1401mm
	:	Height Apx. 1810mm
Dry weight (Approx.)	:	6750kg (without accessories)
Fuel oil	:	ASTM D975 No. 2 - D or BS 2869 class A1 ,A2
Lubricating oil	:	API service CF class or SAE15W-40
Output at ISO 3046 standard air conditions (25°C, 100kPa, 30% relative humidity)		
Stand-by rating	:	1590kW/1500min ⁻¹
Prime rating	:	1450kW/1500min ⁻¹
Fuel consumption ratio at stand-by rating (allowance +5%)	:	204g/kW-hr at 1590kW/1500min ⁻¹
Fuel consumption ratio at prime rating (allowance +5%)	:	204g/kW-hr at 1450kW/1500min ⁻¹
Lub, oil consumption ratio at stand-by rating	:	Within 0.8g/kW-hr
Emission compliance	:	Not certified

5. STANDARD EQUIPMENTS

(1) Power line system

Flywheel	: DWG.NO.37896-21001 SAE J620d 21in, except screw size
Flywheel housing	: DWG.NO.37896-21001 SAE J617c No.00, except screw size
Engine mounting	: DWG.NO.37896-14001 4 points mounting, C = 250mm
Torsional vibration damper	: Viscous type × 2pc

(2) Air intake system

Air cleaner	: DWG.NO.38F96-30351 , S35-5030 4 pcs Paper element type without indicator
Turbocharger	: MITSUBISHI TD Type Model : TD10L
Air cooler	: Jacket water cooled type Plated element type
Air heater	: Not supply

(3) Exhaust system

Exhaust manifold	: Air cooled type with heat insulator
Muffler	: Not supply
Flexible pipe	: DWG.NO.S37-1090 loose supply JIS 350A, L = 335mm, weight 31.6kg
Companion flange	: Not supply
Breather	: DWG.NO.37896-43013 Up side direction type For blow - off to outside of engine room

(4) Lubricating system

Oil pump	: Gear pump type
Capacity of oil pump	: 480L/min (at Engine Speed 1500min ⁻¹)
Lub. oil pressure	: 0.49~0.64 Mpa
Quantity of oil (Approx.)	: Oil pan full level : 200 liter low level : 140 liter Others (filter etc.) : 30 liter Total : 230 liter

- Lub. oil filter (Full flow) : Paper element cartridge type × 4pcs
filter mesh : 20 μ
with by - pass alarm switch
- Lub. oil filter (By - pass flow) : Paper element cartridge type × 1pc
filter mesh
- Lub. oil cooler : Water cooled corrugat : 2 μ
- (5) Cooling system
- Water pump : Gear drive centrifugal type
- Capacity of water pump : 1650 L/min (at Engine Speed 1500min⁻¹)
- Thermostat : Wax pellet type × 4pcs
Open at 71°C ~ 85°C
- Fan : Pusher type steel fan 1530 diameter, Gear drive
Fan speed ratio i = 0.568
- Quantity of Coolant : Approx.170L (only Engine)
- Radiator : Not supply
- Radiator piping : Not supply
- (6) Fuel system
- Fuel inlet pipings : DWG.NO.37896-62112 loose supply
flexible hose (Rc 3/4 joint)
- Fuel return pipings : DWG.NO.37896-61312 loose supply
flexible hose (Rc 3/4 joint)
- Fuel overflow of Inj. Pump and fuel leak - off of Nozzle have to return to fuel tank
- Injection pump : Bosch type "PS8" without timer
- Feed pump : Piston type with priming pump
- Injection Nozzle : Hole type 0.325mm×10 holes
- Fuel filter : Paper element cartridge type filter mesh : 5 μ
- (7) Control system
- Governor : DWG.NO.37896-63005
TOHO Electronic speed governor
Speed droop : 0 ~ 5% adjustable

Actuator	: DWG.NO.S13-1761 Supply voltage : DC24V± 20% Current consumption At starting : 13A Normal operation : 0.5 ~ 2A Min. Supply voltage : DC16V50%ED
Controller	: DWG.NO.S13-1042 loose supply Model : XS-400B-03 (04410-33100) Supply voltage : DC24V± 20%
Potentiometer	: Not supply
Connector	: DWG.NO.S13-1022 loose supply From actuator to controller 5000mm length
Magnetic pick up	: DWG.NO.S13-2011 With connector
Cable	: DWG.NO.S13-2020 loose supply From magnetic pick up to controller 4300mm length
 (8) Starting system	
Starter switch	: Not supply
Starting motor	: DWG.NO.38E96-66051 DC24V, 7.5KW × 2pcs Reduction type with relay to turn on electricity to solenoid coil The provided starting motor does not include the following function. Function to prevent energising of starting motor while engine is running
Auto magnetic engage relay	: Not supply
Current of starter	: Rush 1250A Cranking 400A (Ambient temp : 5°C, Lub. oil : SAE No. 30)

Alternator	: DWG.NO.38E96-68051 DC28V, 55A, with voltage regulator
Connector for alternator	: Not supply
Recommended battery capacity	: DC24V, 400AH Not supply
Battery switch	: Not supply
(9) Stopping system	: DWG.NO.37896-87502
Automatic stop	Automatically shut - down by stop solenoid and electronic governor power off simultaneously
Stop solenoid	: DWG.NO.S13-0282 Energized to run type DC24V, 30.7A(pull), 0.58A(hold)
Manual stop	: By stop lever
(10) Safety device	
Alarm switches	: DWG.NO.37896-90207
Alarm and trip	
Low oil press. switch	: DWG.NO.S11-0796 (04442-45400) Diaphragm type : 0.15 MPa switch on
High water temp. switch	: DWG.NO.S11-0551 (04442-34500) Wax type : 98°C switch on
Alarm	
Oil filter alarm switch	: DWG.NO.S11-1371 Piston type : 0.15 MPa switch on
Oil filter alarm lamp	: Not supply
Air filter alarm indicator	: DWG.S11-0920 Mechanical type : 6.2kPa switch on
(11) Meter and sensor	
Meter and sensor	: DWG.NO.38F96-90152
Tachometer	: Not supply
Magnetic pick up	: DWG.NO.S13-2011 For tachometer, pin-joint type
Cable	: For magnetic pick up, Not supply

Thermometer : For jacket water and lub. oil temp.
Not supply
Pressure gage : For lub. oil press.
Not supply
Connector : 2 poles for pressure gage loose supply
DWG.NO.S14-0330
Thermometer : For exhaust gas temp.
Not supply

(12) Others

Turning device : DWG.NO. 37896-71001
Gear type, for maintenance
Tools : Not supply
Spare parts : Not supply

Declaration:

To maintain and optimize product performance and reliability, we will do some necessary change timely to product or parts in this specification without altering the basic parameters. If you need more information, please refer to our company's official website or consult us directly.

6. ACCESSORIES (Loose supply parts)

NO.	PARTS NO.	PATRS NAME	Q'TY	DWG.NO.	
1	38G30-03101	AIR CLEANER ASSY.	2	S35-5030	38F96-30351
2	38G30-05301	AIR CLEANER ASSY.	2	S35-5030	
3	38G30-02201	CAP ASSY	4	S35-5230	
4	38G30-08301	BAND	4	S35-5110	
5	45686-76402	PIPE, AIR	4		
6	32330-09400	O-RING	8		
7	47220-31400	ELBOW, HOSE	2	S35-0720	
8	47220-30400	ELBOW, HOSE	2	S35-0701	
9	47520-71700	PIPE, AIR	2		
10	47520-71800	PIPE, AIR	2		
11	47220-30500	HOSE, RUBBER	4	S35-0711	
12	05317-51801	CLAMP	16		37896-43013
13	38G32-02400	PIPE,FLEXIBLE	1	S37-1090	
14	45955-22160	HOSE, VINYL	1		
15	05317-51001	CLAMP	4		37896-61312
16	47510-59300	PIPE, BREATHER	1		
17	45950-51700	PIPE,FLEXIBLE	1		37896-62112
18	45950-11300	CONNECTOR	1		
19	45950-51700	PIPE,FLEXIBLE	1		
20	45950-11300	CONNECTOR	1		37896-63005
21	04410-33100	CONTROLLER	1	S13-1042	
22	04410-32902	CONNECTOR, ACTUATOR	1	S13-1022	
23	04410-43500	CABLE, PICK UP	1	S13-2020	38F96-90152
24	MH052231	CONNECTOR	1	S14-0330	
25	47220-34401	INDICATOR	4	S11-0920	37896-90207

MHI CONFIDENTIAL

NO.	PARTS NAME	SIZE	REFERENCE
1	FLYWHEEL & HOUSING		37896-21001
2	OIL PRESS. GAGE UNIT JOINT	Rc1/8	37896-01008
3	OIL PRESS. SWITCH JOINT	Rc1/8	
4	OIL PRESS. SWITCH JOINT	Rc3/8	
5	THERMOMETER UNIT JOINT	Rc1/2	
6	THERMOSWITCH JOINT	Rc1/2	
7	OIL PAN (A) JOINT	M16x1.5	
8	OIL PAN (B) JOINT	M20x1.5	
9	OIL PAN (C) JOINT	M36x1.5	
10	OIL PAN (D) JOINT		
11	AIR PRESS. GAGE JOINT	Rc1/8	
12	PICKUP JOINT	5/8-18UNF	37896-01008
13	GOVERNOR		
14	FUEL INLET PIPE JOINT	Rc3/4	37896-01008
15	FUEL RETURN PIPE JOINT	Rc3/4	37896-01008
16	FUEL FILTER		
17	FUEL PRESS. SWITCH JOINT	M14x1.5	37896-01008
18	FUEL PRESS. SWITCH JOINT	Rc3/8	37896-01008
19	FUEL INJECTION PUMP		
20	OIL FILLER		
21	OIL LEVEL GAGE		
22	OIL FULL-FLOW FILTER		
23	OIL BY-PASS FILTER		
24	OIL BY-PASS ALARM SWITCH		37896-01008
25	BREATHER		
26	WATER INLET PIPE JOINT	80A	
27	WATER OUTLET PIPE JOINT		37896-01008
28	WATER DRAIN COCK		
29	EXHAUST FLANGE	350A	
30	THERMOMETER, EX. JOINT	G3/4	37896-01008
31	STOP SOLENOID		

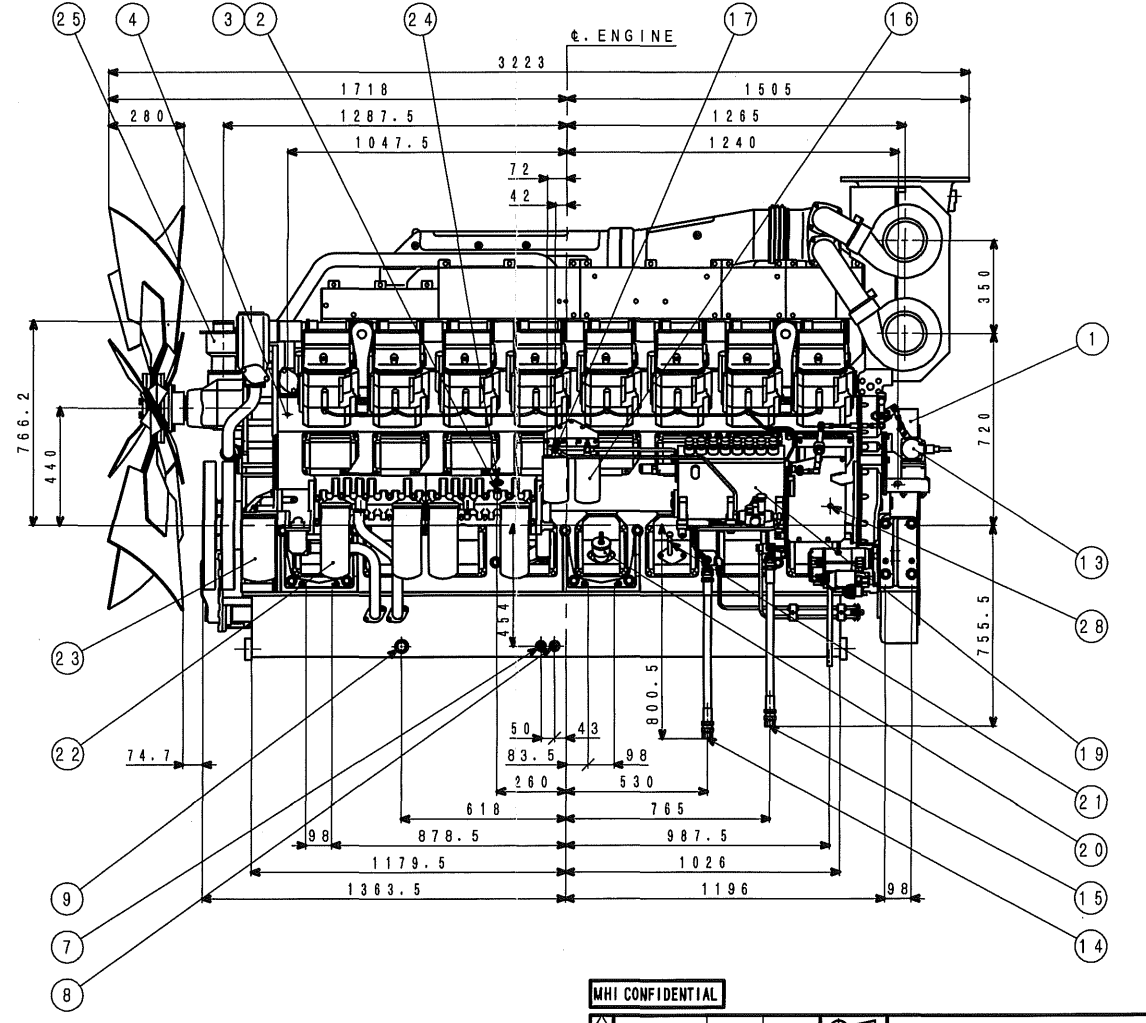
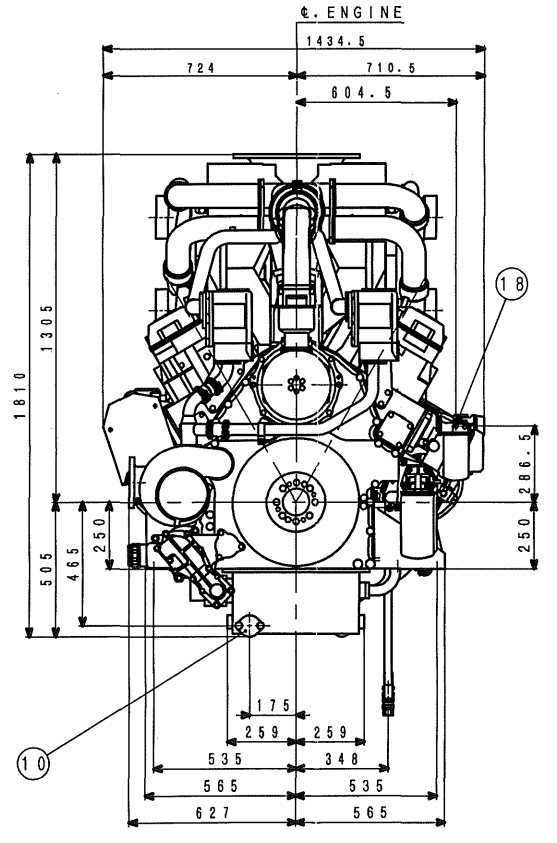
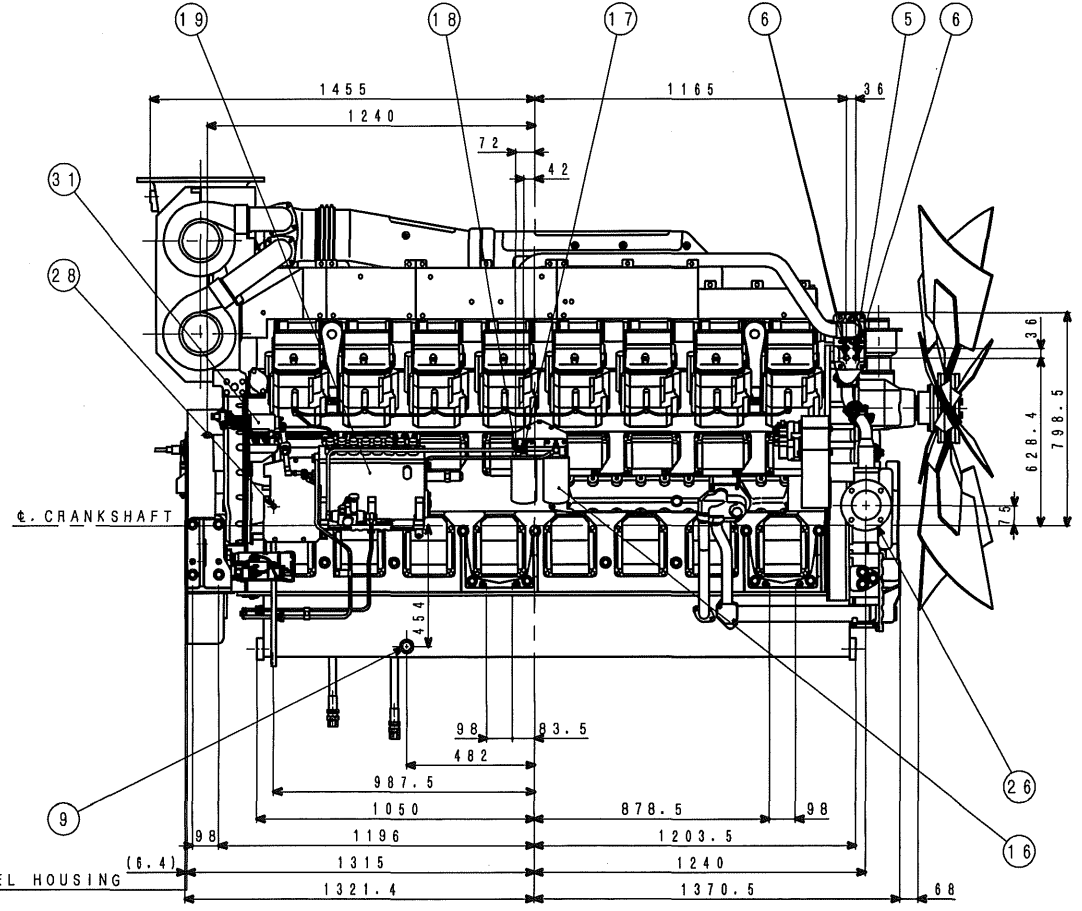
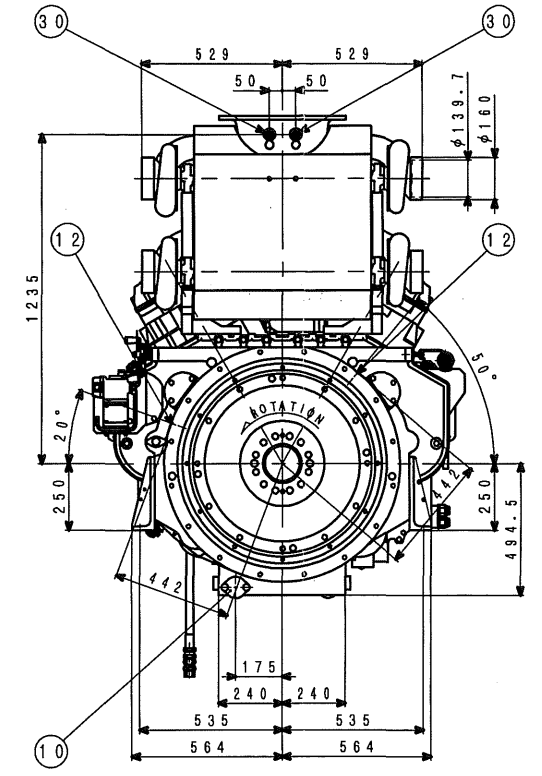
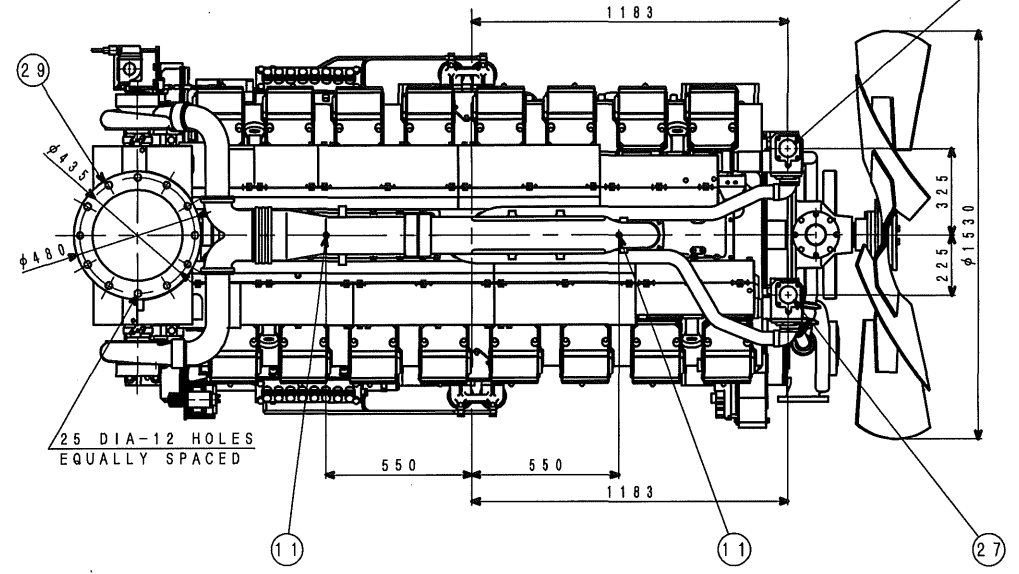

NOTES (1) THIS DRAWING SHOWS S16R-PTA WITH FAN.
(2) THIS TURBOCHARGER IS MHI TD10L-38F-28 FOR 1500min⁻¹ SPEC.
(3) THE GOVERNOR ON THIS DRAWING IS ELECTRIC GOVERNOR.
(4) THIS MOUNTING HEIGHT FROM THE CRANK SHAFT CENTER IS 250mm.

MHI CONFIDENTIAL

S16R-PTA
DIESEL ENGINE

三菱重工業株式会社
MITSUBISHI HEAVY INDUSTRIES LTD.

図面番号 38F96-00251

DATE: 3.25

DESIGNER: T. HASEGAWA
CHECKER: K. SAKAMOTO

SCALE: 1:10

N/C

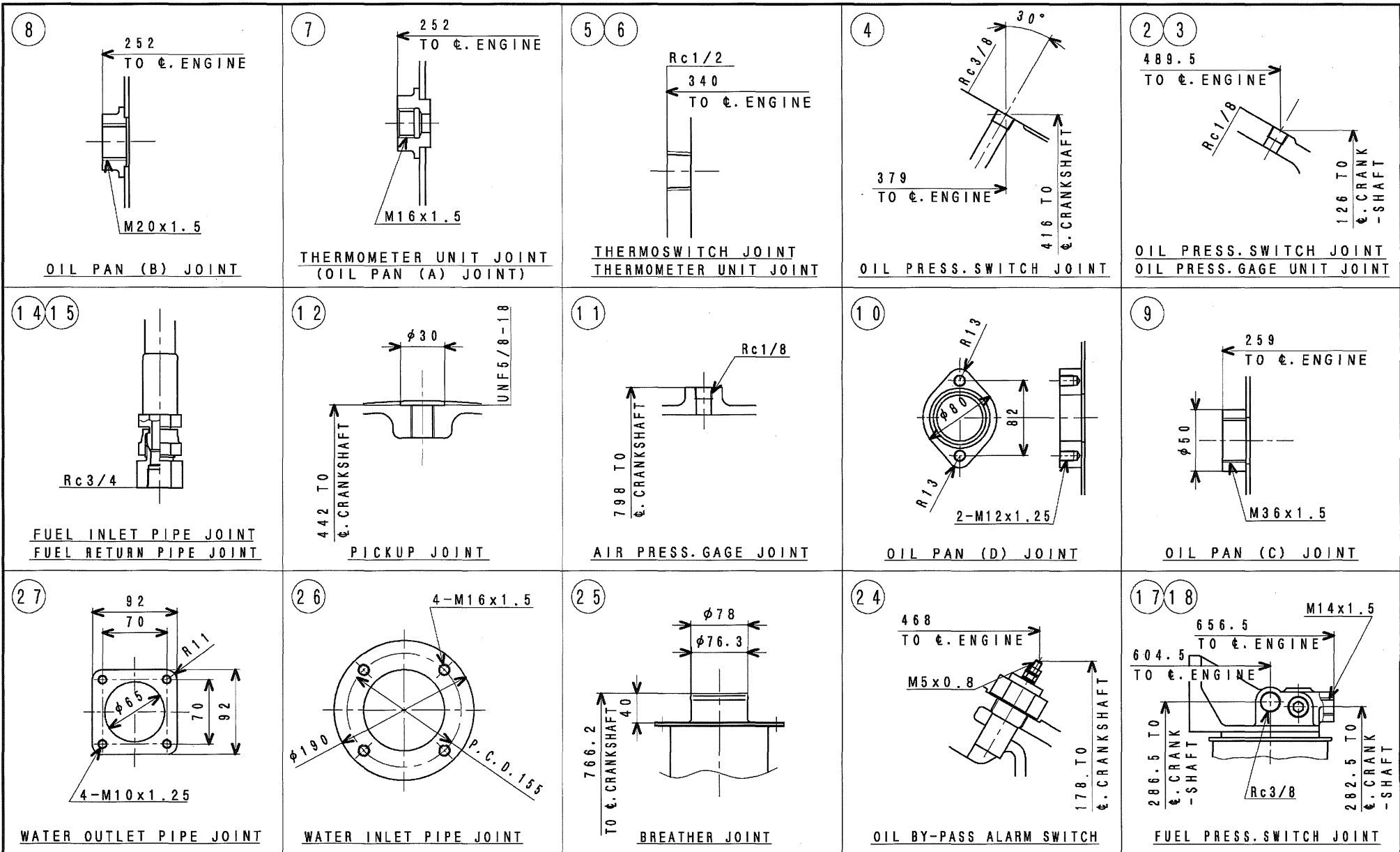

MHI CONFIDENTIAL

注記 (1) 本図は、PTAファン付用のジョイント詳細図である。

CHG	EO-NO	DATE	CHK
橋	4590-H494	'13. 6. 21	谷戸
認可 APPD	橋	検図 CHK	小倉
		製図 DRN	谷戸
			1999. 10. 15

3rd ANGLE PROJECTION
尺度 SCALE

S16R
JOINT DETAIL

三菱重工業株式会社 汎用機・特車事業本部
MITSUBISHI HEAVY INDUSTRIES, LTD. GENERAL MACHINERY & SPECIAL VEHICLE HEADQUARTERS.

図面番号
DRAWING No. 37896-01008

旧引
汎特
2013
6. 21

M/C

3 新図
4 組立品
5 切替品
6 その他(購入品)

1 旧引図
2 組立図
3 銅鋳造部品
4 銅鋳造部品
5 銅鋳造部品
6 その他(購入品)

30

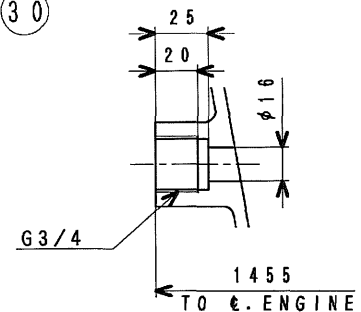

THERMOMETER, EX. JOINT

旧引
▲
況特
2013
6.21

M/C

3rd ANGLE PROJECTION		S16R	
尺度 SCALE		JOINT DETAIL	
三菱重工業株式会社 汎用機・特車事業本部			
MITSUBISHI HEAVY INDUSTRIES, LTD. GENERAL MACHINERY & SPECIAL VEHICLE HEADQUARTERS.			
CHG	ED-NO	DATE	CHK
↑	4590-H494	'13. 6.21	谷戸
認可 APPD	橋	検図 CHK	製図 DRN
	口	小倉	谷戸
		中村	1999.10.15
図面番号 DRAWING No.		37896-01008	
3 新図		① 組立図	
④ 旧引図		2 鋳造部品	
サイズ A 3		3 板金溶接品	
		4 組立品	
		5 切削品	
		6 その他(購入品)	

MHI CONFIDENTIAL

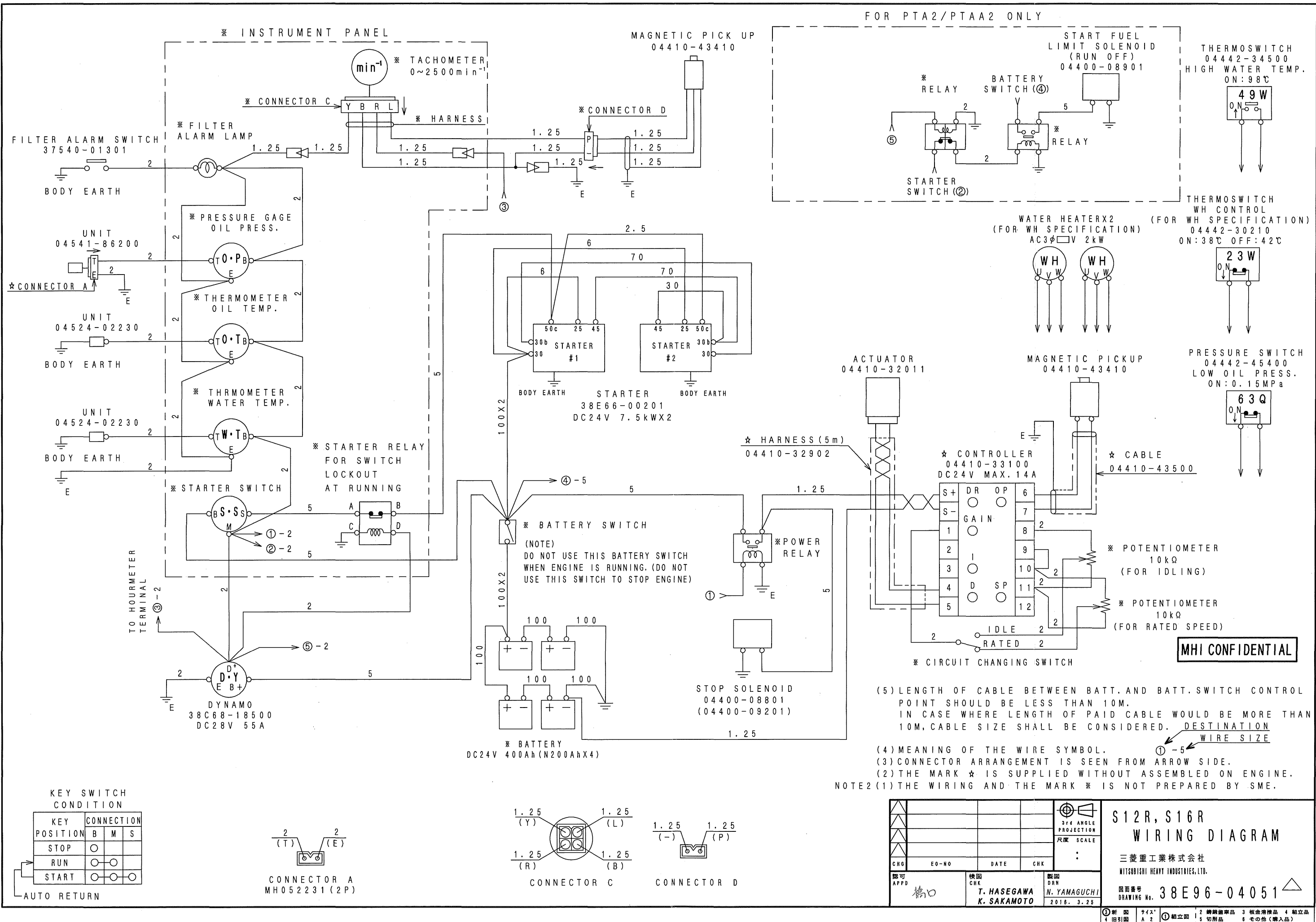

FOR PTA2/PTAA2 ONLY

MHI CONFIDENTIAL

(5) LENGTH OF CABLE BETWEEN BATT. AND BATT. SWITCH CONTROL POINT SHOULD BE LESS THAN 10M. IN CASE WHERE LENGTH OF PAID CABLE WOULD BE MORE THAN 10M, CABLE SIZE SHALL BE CONSIDERED. DESTINATION WIRE SIZE

(4) MEANING OF THE WIRE SYMBOL. ①-5

(3) CONNECTOR ARRANGEMENT IS SEEN FROM ARROW SIDE.

(2) THE MARK ☆ IS SUPPLIED WITHOUT ASSEMBLED ON ENGINE.

NOTE 2 (1) THE WIRING AND THE MARK * IS NOT PREPARED BY SME.

KEY SWITCH CONDITION

KEY POSITION	B	M	S
STOP	○		
RUN	○	○	
START	○	○	○

AUTO RETURN

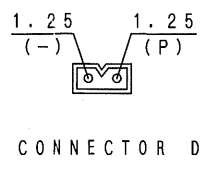
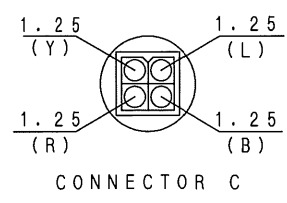
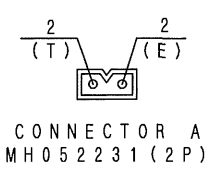

CHG	EO-NO	DATE	CHK
認可 APPD	橋口	検出 CHK	T. HASEGAWA K. SAKAMOTO
		製図 DRW	N. YAMAGUCHI
			2016. 3. 25

S12R, S16R
WIRING DIAGRAM

三菱重工業株式会社
MITSUBISHI HEAVY INDUSTRIES, LTD.

図面番号
DRAWING No. 38E96-04051

①新図 ②サイズ ③組立図 ④参照品 ⑤切取品 ⑥板金溶接品 ⑦組立品 ⑧その他(購入品)

M/C

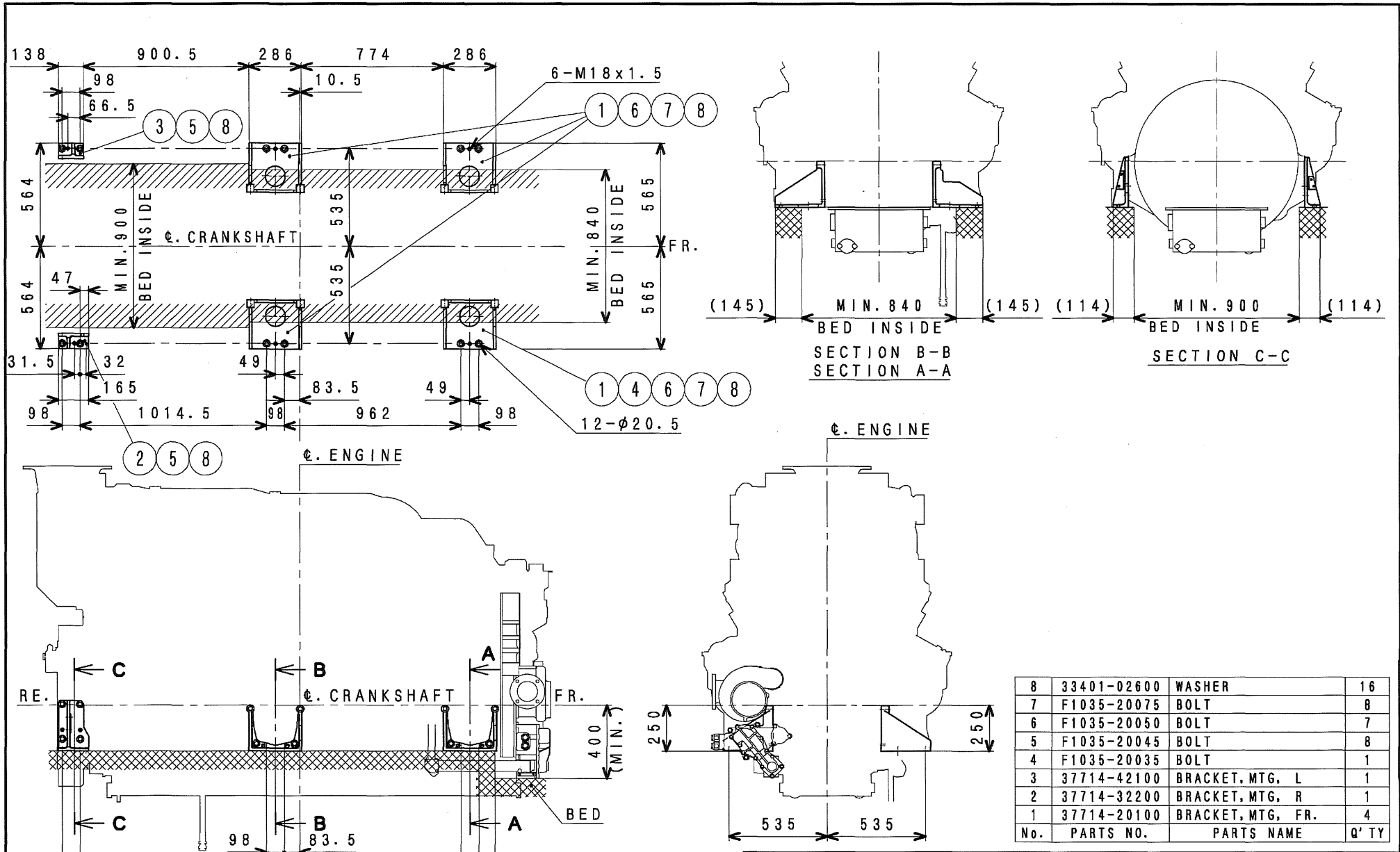

8	33401-02600	WASHER	16
7	F1035-20075	BOLT	8
6	F1035-20050	BOLT	7
5	F1035-20045	BOLT	8
4	F1035-20035	BOLT	1
3	37714-42100	BRACKET, MTG. L	1
2	37714-32200	BRACKET, MTG. R	1
1	37714-20100	BRACKET, MTG. FR.	4
No.	PARTS NO.	PARTS NAME	Q'TY

4	4590-E901	'08.10.6	齊藤
3	4590-5477	'99.8.6	福田
2	4590-5002	'99.2.26	仁尾
5	4590-H421	'12.11.19	谷戸
CHG	ED-NO	DATE	CHK
認可 APPD	橋	検図 CHK	仁 福 尾 田
		製図 DRN	谷 戸
		1998. 8. 20	

S16R
MOUNTING
三菱重工業株式会社 汎用機・特車事業本部
MITSUBISHI HEAVY INDUSTRIES, LTD. GENERAL MACHINERY & SPECIAL VEHICLE HEADQUARTERS.
図面番号 37896-14001
DRAWING No. 5

MHI CONFIDENTIAL

注記 (1) 本図は、マウンティングセンターハイトC=250用である。

4590-4536	'98.8.18	福田
-----------	----------	----

旧引
汎特
2013
2.8

M/C

3 新図 サイズ
① 旧引図 A 3
① 組立図
2 脚跡部用品
5 初別品
3 板金浴換品
6 その他(購入品)
4 組立品
9

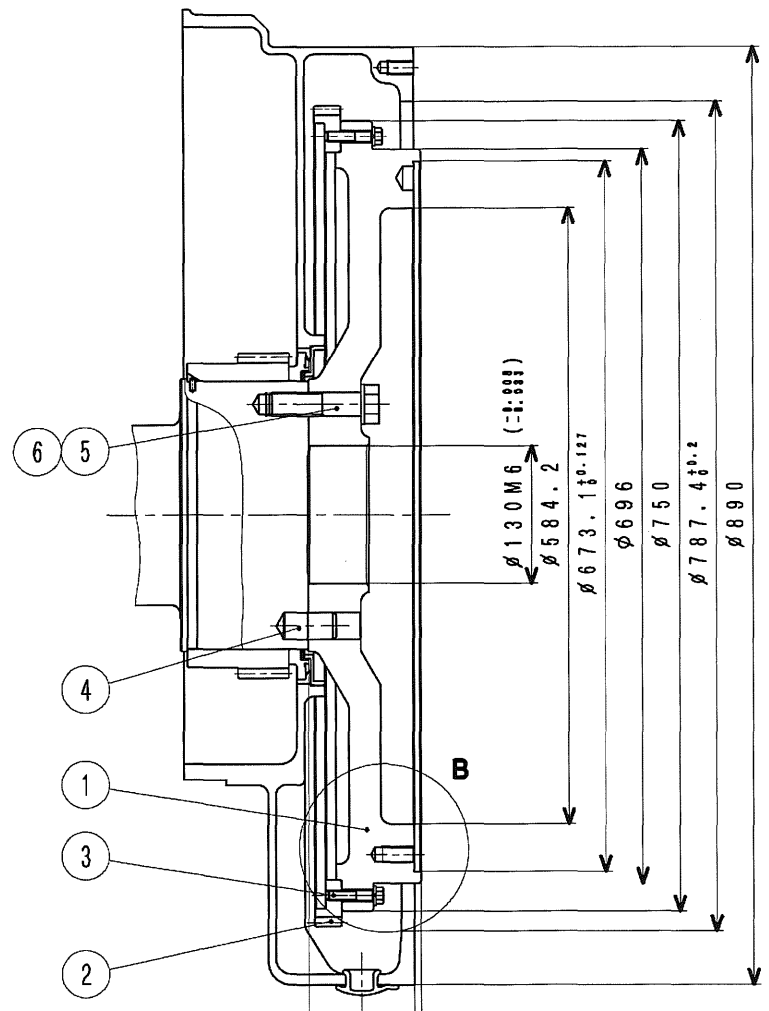

1214.9 TO ϕ . ENGINE 106.5
 1315 TO ϕ . ENGINE 6.4
 1321.4 TO ϕ . ENGINE

SECTION A-A

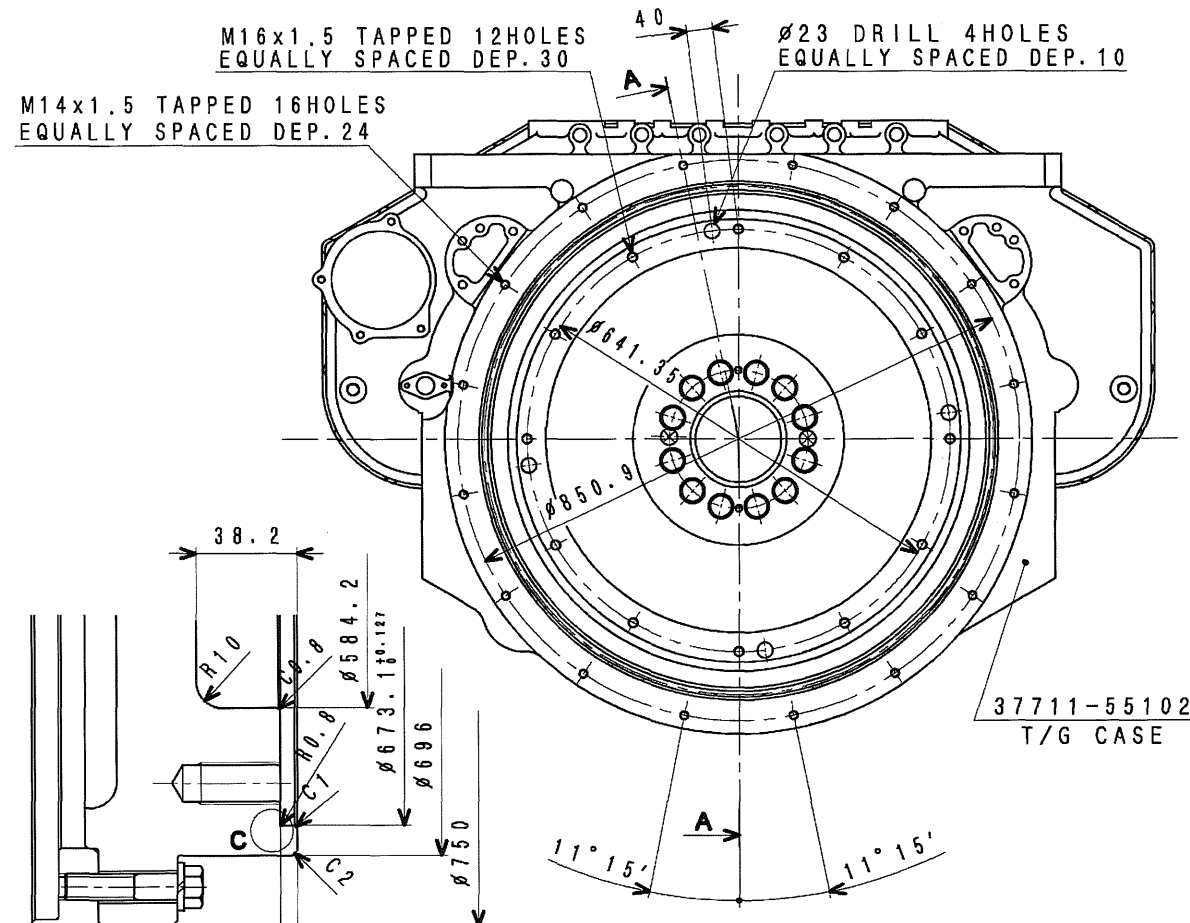

M16x1.5 TAPPED 12HOLES EQUALLY SPACED DEP. 30
 M14x1.5 TAPPED 16HOLES EQUALLY SPACED DEP. 24
 ϕ 23 DRILL 4HOLES EQUALLY SPACED DEP. 10

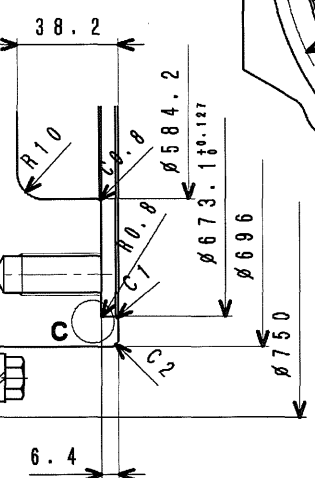

DETAIL B

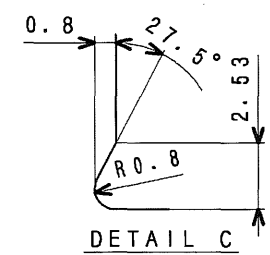

DETAIL C

37711-55102
T/G CASE

6	33707-11701	WASHER	12
5	F1035-22090	BOLT	12
4	37820-04600	PIN, DOWEL	2
3	F1805-10045	BOLT	12
2	37721-20201	GEAR, RING	1
1	37721-00601	FLYWHEEL	1
No.	PARTS NO.	PARTS NAME	Q' TY

MHI CONFIDENTIAL

3	4590-G654	'11. 3.28	斉藤
2	4590-D678	'07.10. 4	斉藤
1	4591-0261	'03. 9.12	福田
CHG	ED-NO	DATE	CHK
認可 APPD	橋	換図 CHK	竹 谷
			福田
		製図 DRN	谷 戸
			1997. 8. 7

S16R
 FLYWHEEL & HOUSING
 三菱重工業株式会社 汎用機・特車事業本部
 MITSUBISHI HEAVY INDUSTRIES, LTD. GENERAL MACHINERY & SPECIAL VEHICLE HEADQUARTERS.
 図面番号 37896-21001

注記 (2) 本図のフライホイールは、部番37721-00061 F/W ASSY. に含まれる。
 (1) 本図は、標準フライホイール&ハウジングであり、SAE J620c 21inフライホイール及びSAE 617b NO. 00フライホイールハウジングに準拠する。

旧引
 況特
 2011
 12.12

FULL-CAD

3 新図
 ① 旧引図
 サイズ
 A 3
 ② 組立図
 2 鋳造部品
 5 切削品
 3 板金接合品
 6 その他(購入品)
 4 組立品

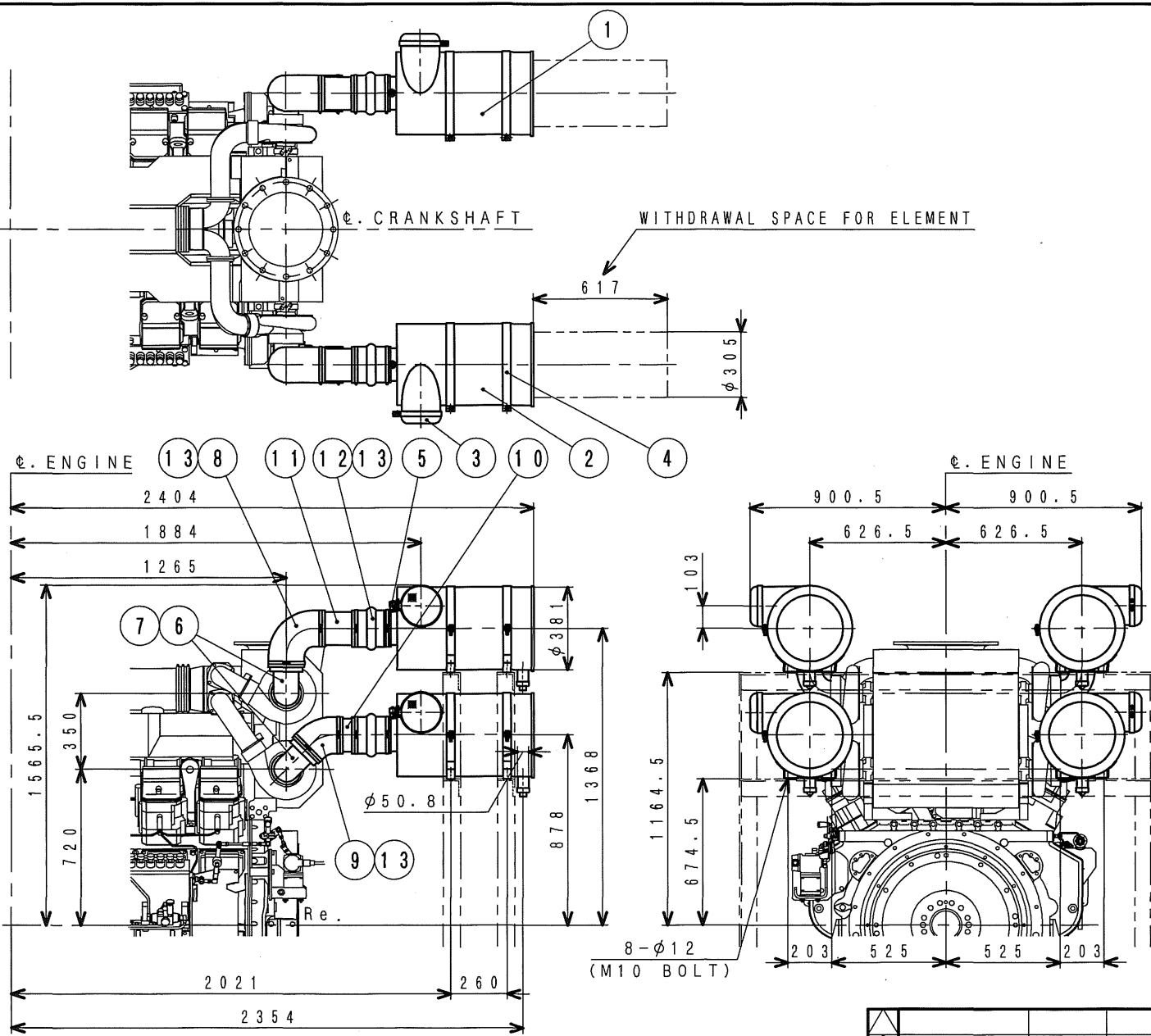

☆	13	05317-51801	CLAMP	16
☆	12	47220-30500	HOSE, RUBBER	4
☆	11	47520-71800	PIPE, AIR	2
☆	10	47520-71700	PIPE, AIR	2
☆	9	47220-31400	ELBOW, HOSE (45°)	2
☆	8	47220-30400	ELBOW	2
☆	7	32330-09400	O-RING	8
☆	6	45686-76402	PIPE AIR (Fr)	4
☆	5	47220-34401	INDICATOR	4
☆	4	38G30-08301	BAND ASSY, D387	8
☆	3	38G30-02201	CAP, AIR CLEANER	4
☆	2	38G30-05301	AIR CLEANER ASSY	2
☆	1	38G30-03101	AIR CLEANER ASSY	2
	No.	PARTS NO.	PARTS NAME	Q'TY

NOTE (1) THE ☆ MARKED PARTS ARE LOOSE SUPPLY.

MHI CONFIDENTIAL

CHG	EO-NO	DATE	CHK	3rd ANGLE PROJECTION 尺度 SCALE
認可 APPD	橋口	検図 CHK	T. HASEGAWA K. SAKAMOTO	製図 DRN N. YAMAGUCHI 2016. 3. 25

S16R-PTA
AIR CLEANER
三菱重工業株式会社
MITSUBISHI HEAVY INDUSTRIES, LTD.

図面番号 38F96-30351
DRAWING No.

① 新図 ② 再入 ③ 組立図 ④ 2 鋼線織網品 ⑤ 3 板金溶接品 ⑥ 4 組立品 ⑦ 1 旧引図 ⑧ 3 切削品 ⑨ 5 8 その他(購入品)

M/C

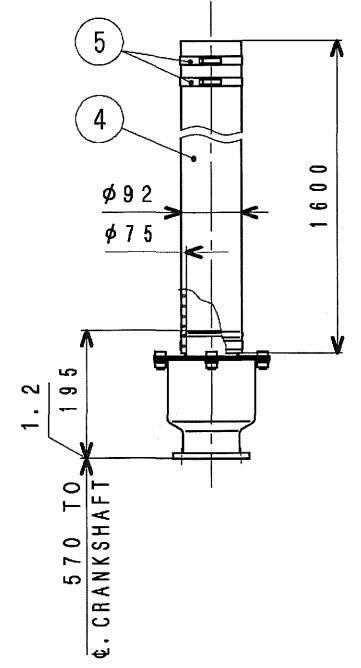
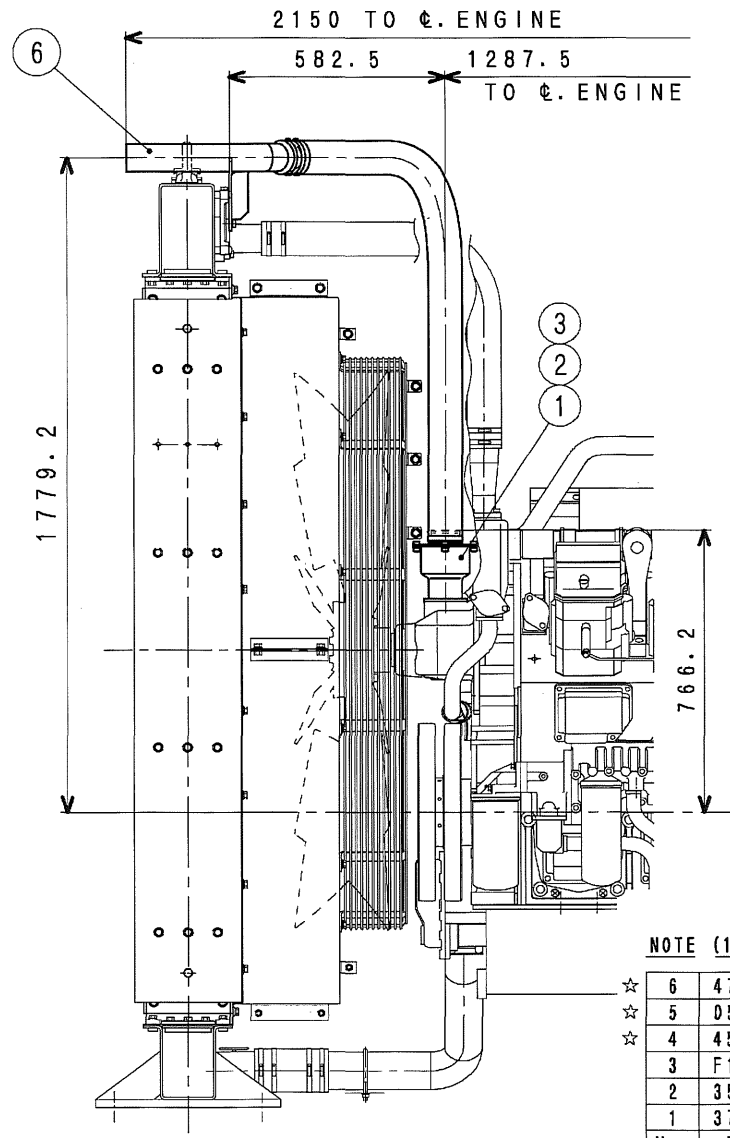
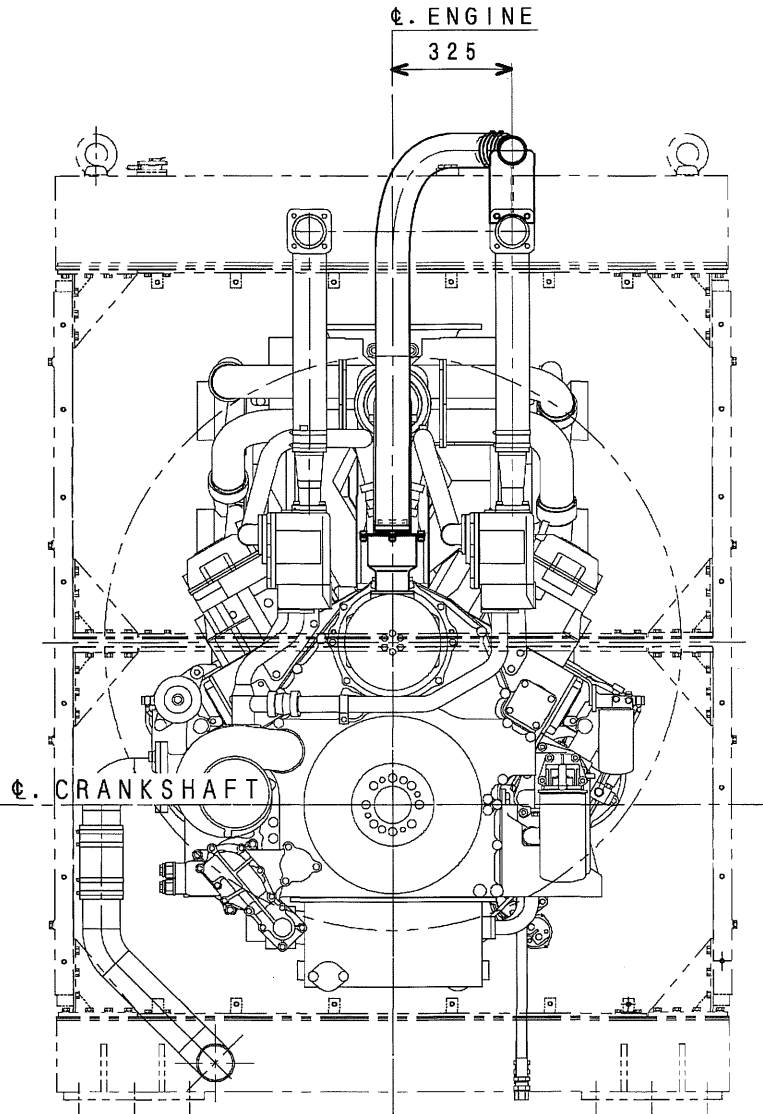

DETAIL OF BREATHER

NOTE (1) THE ☆ MARKED PARTS ARE LOOSE SUPPLY.

No.	PARTS NO.	PARTS NAME	Q'TY
☆ 6	47510-59300	PIPE, BREATHER	1
☆ 5	05317-51001	CLAMP	4
☆ 4	45955-22160	HOSE, VINYL	1
3	F1805-12025	BOLT	4
2	35B43-01500	PACKING	1
1	37743-00501	BREATHER ASSY.	1

MHI CONFIDENTIAL

注記 (1) 本図は、オイルフィラ装置前側上向きブリーザ及びパイピング図である。

CHG	EO-NO	DATE	CHK	3rd ANGLE PROJECTION	尺笈 SCALE
認可 APPD	橋	検図 CHK	塚 中	製図 DRN	谷 戸
	口	本 村		2012.11.28	

S16R
BREATHER
三菱重工業株式会社 汎用機・特車事業本部
MITSUBISHI HEAVY INDUSTRIES, LTD. GENERAL MACHINERY & SPECIAL VEHICLE HEADQUARTERS.
図面番号 37896-43013
DRAWING No.

出図
汎特
2013
2.8

M/C

③ 新図 サイズ A 3
④ 旧引図
① 組立図
② 鍛造部品
③ 板金溶接品
④ 組立品
⑤ 切削品
⑥ その他(購入品)

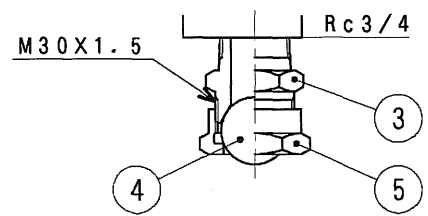
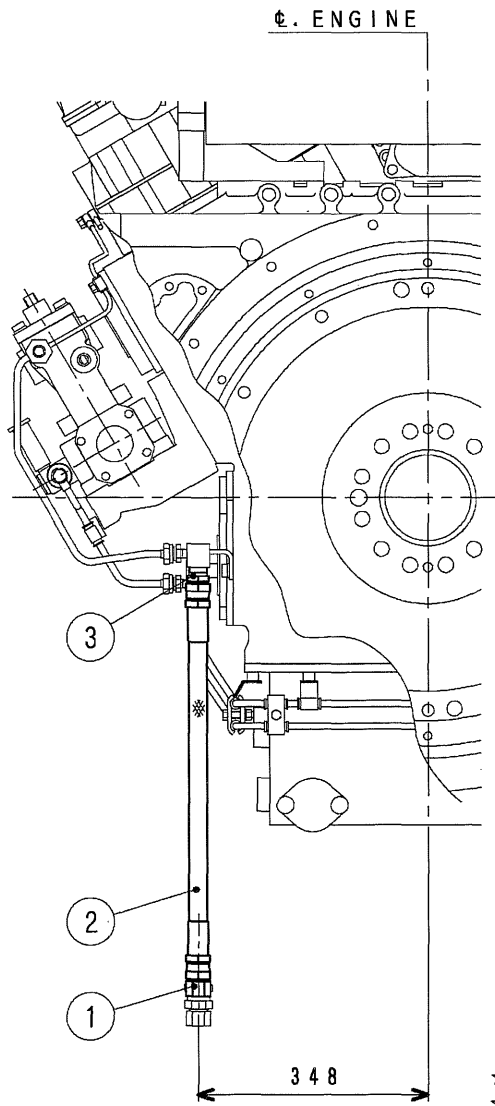
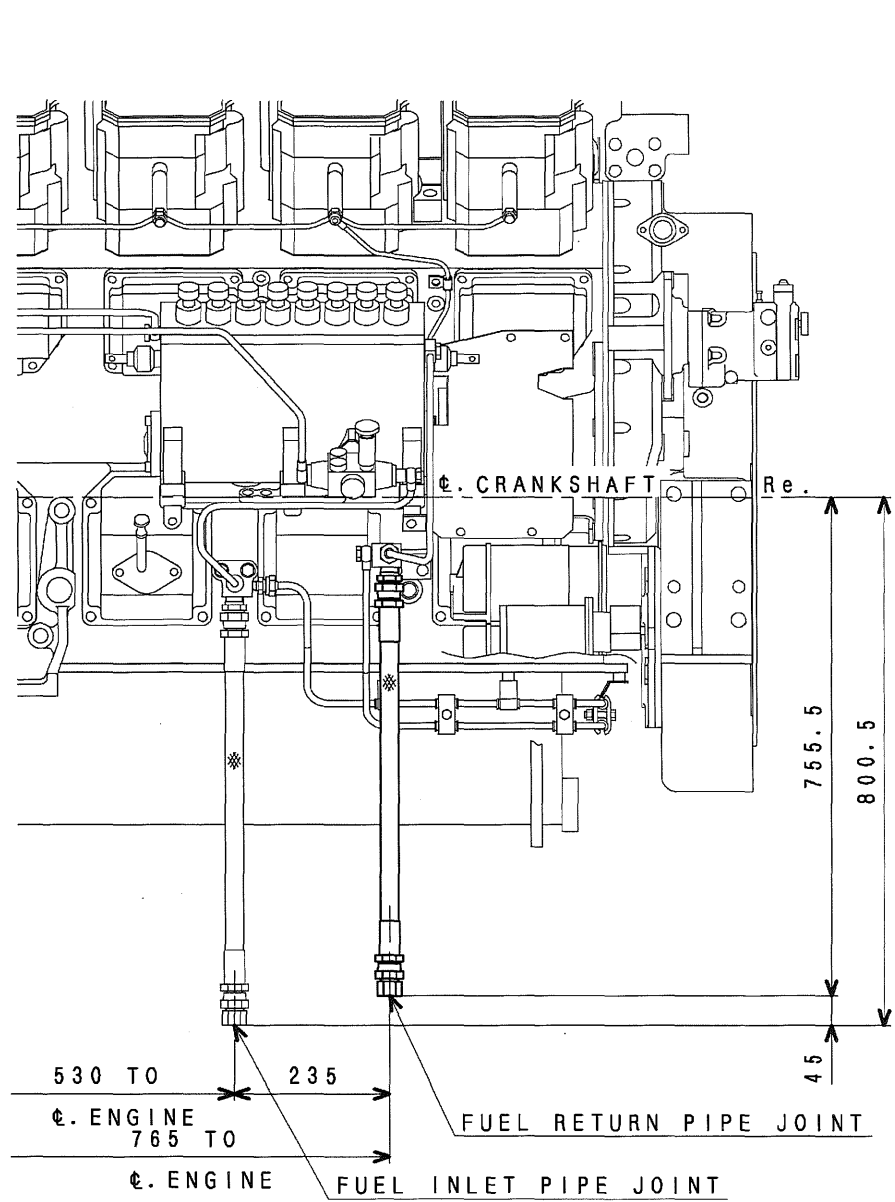

FUEL RETURN PIPE JOINT

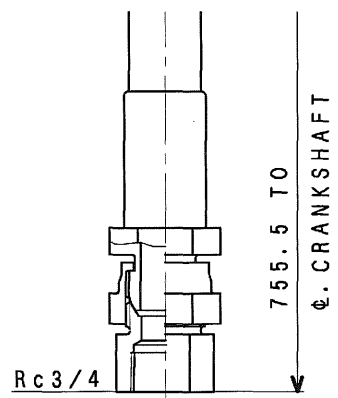

FUEL RETURN PIPE JOINT

NOTE (1) THE ☆ MARKED PARTS ARE LOOSE SUPPLY.

NO.	PARTS NO.	PARTS NAME	Q'TY
5	F4521-20000	NUT, UNION	1
4	F8000-32000	STEEL BALL, BEARING	1
3	F4540-20000	CONNECTOR	1
☆ 2	45950-51700	PIPE, FLEXIBLE	1
☆ 1	45950-11300	CONNECTOR	1

MHI CONFIDENTIAL

注記 (1) 本図は、図番37896-61305に対しフレキホース及び先端コネクタを別送品としたものである。
 (2) 本図の符号④⑤は、燃料戻り口盲栓である。(エンジン出荷状態)

CHG	EO-NO	DATE	CHK
認可 APPD	橋	換図 CHK	三谷 上戸
製図 DRW		浅沼	
2008.12.10			

S16R
 FUEL RETURN PIPING
 三菱重工業株式会社 汎用機・特車事業本部
 MITSUBISHI HEAVY INDUSTRIES, LTD. GENERAL MACHINERY & SPECIAL VEHICLE HEADQUARTERS.
 図面番号 37896-61312
 DRAWING No.

出図
 汎特
 2008
 12.12

FULL-CAD

① 新図 ② 訂正 ③ 板金接接品 ④ 組立品
 ⑤ 旧引図 ⑥ A 3 ⑦ 組立図 ⑧ 5 初刷品 ⑨ 6 その他(購入品)

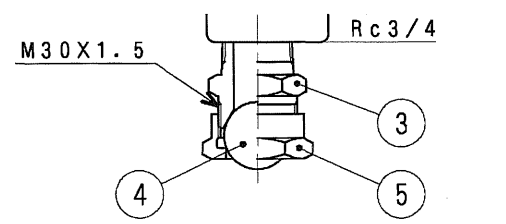
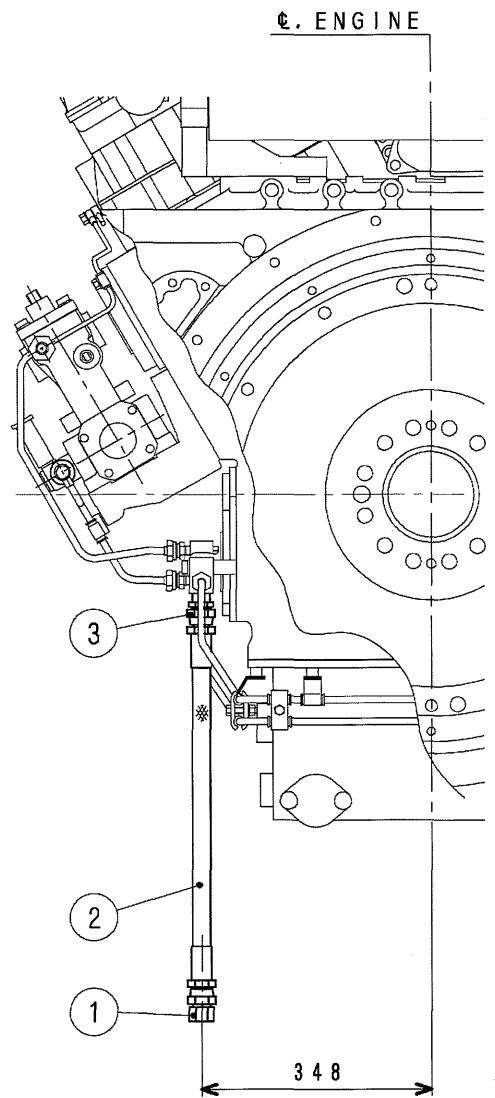
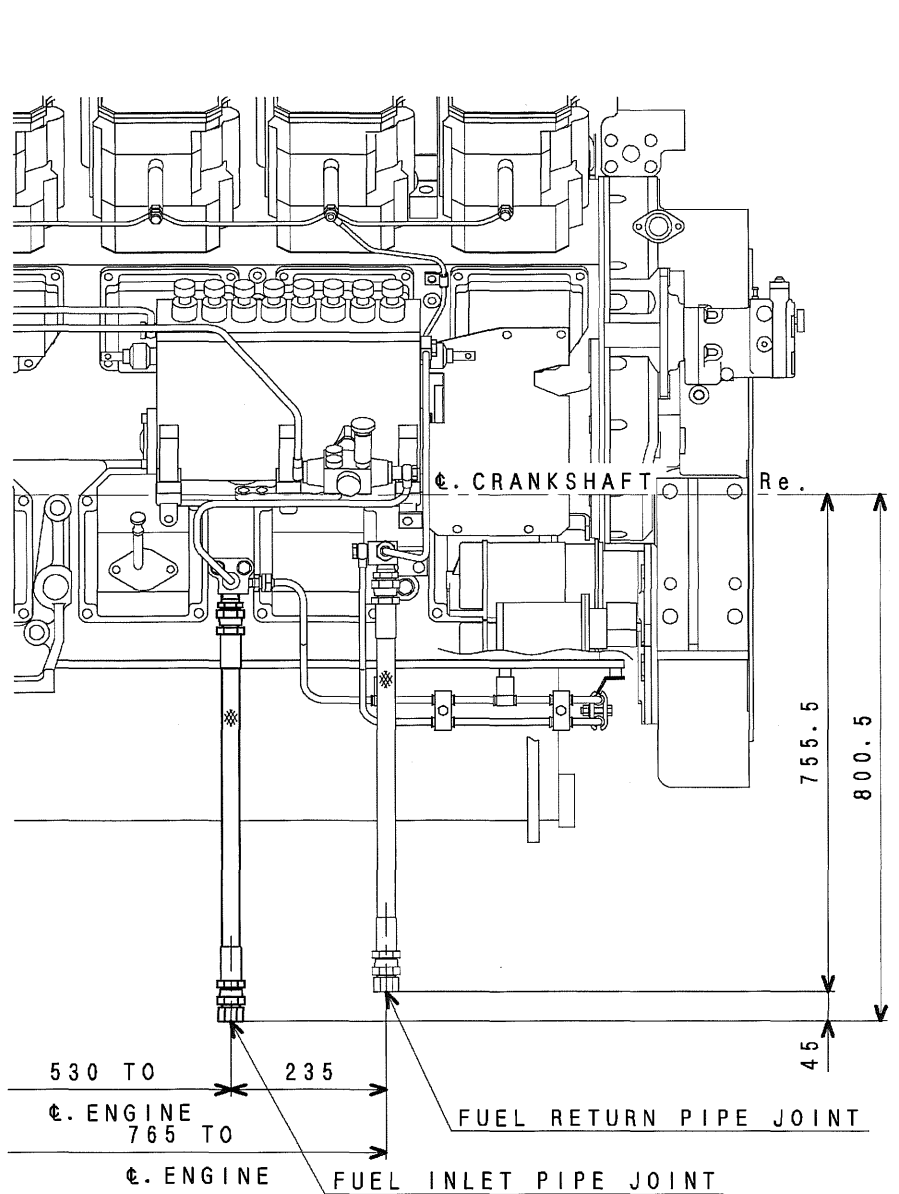

DETAIL OF INLET PIPE JOINT

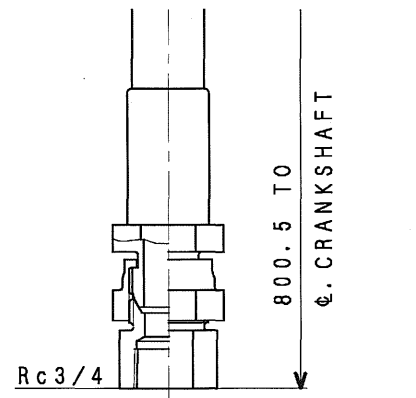

DETAIL OF INLET PIPE JOINT

NOTE (1) THE ☆ MARKED PARTS ARE LOOSE SUPPLY.

NO.	PARTS NO.	PARTS NAME	Q'TY
5	F4521-20000	NUT, UNION	1
4	F8000-32000	STEEL BALL, BEARING	1
3	F4540-20000	CONNECTOR	1
☆ 2	45950-51700	PIPE, FLEXIBLE	1
☆ 1	45950-11300	CONNECTOR	1

MHI CONFIDENTIAL

注記 (1) 本図は、図番37896-62101に対しフレキホース及び先端コネクタを別送品としたものである。
 (2) 本図の符号(4)(5)は、燃料入口盲栓である。(エンジン出荷状態)

CHG	ED-NO	DATE	CHK
認可 APPD	橋	検図 CHK	三谷 上戸
製図 DRN		浅沼	
2008.12.10			

S16R
FUEL INLET PIPING
 三菱重工業株式会社 汎用機・特車事業本部
 MITSUBISHI HEAVY INDUSTRIES, LTD. GENERAL MACHINERY & SPECIAL VEHICLE HEADQUARTERS.
 図面番号 37896-62112
 DRAWING No.

出図

汎特
 2008
 12.12

FULL-CAD

① 新図 ② 組立図 ③ 贈送品 ④ 粗立品
 ④ 旧図 ⑤ 5 初刷品 ⑥ その他(購入品)

1316.5 TO ϕ . ENGINE
 1296.5 TO ϕ . ENGINE
 1179.5 TO ϕ . ENGINE
 817.5 TO ϕ . ENGINE

STOP FULL
 33.7°

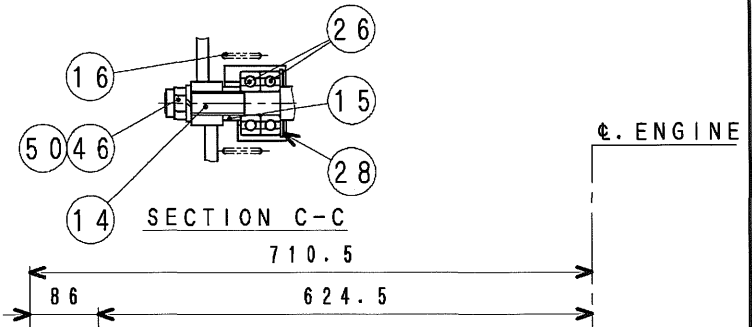
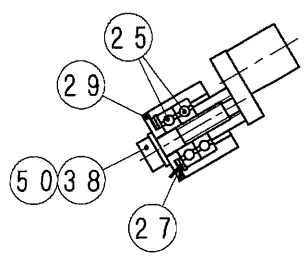
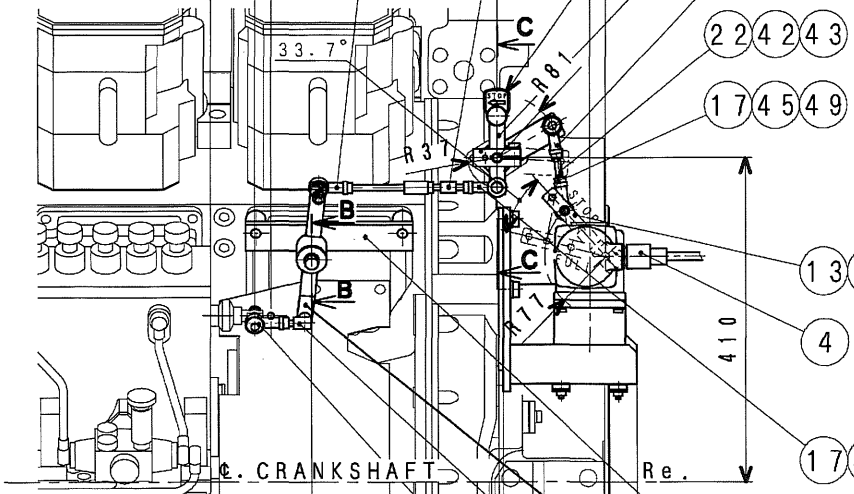

SECTION B-B

SECTION C-C

49 36 23

1

51 40 7

286
 145
 141

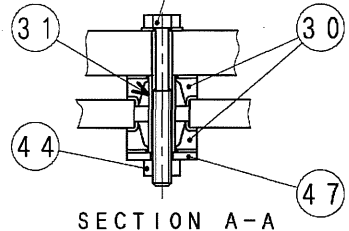

MHI CONFIDENTIAL

945.5 TO ϕ . ENGINE

1181 TO ϕ . ENGINE
 1187 TO ϕ . ENGINE
 1356 TO ϕ . ENGINE

注記 (2) 整定周波数範囲: 3575~5790Hz、エンジン回転数: 1500/1800rpm共用
 (1) 本図は、SG4017BR電子ガバナコントロールボックス(ユニット)仕様である。

2	4590-G659	'11. 3.28	斉藤
1	4590-4983	'99. 2.25	福田
CHG	EO-NO	DATE	CHK
認可 APPD	橋	検図 CHK	竹 福 谷 田
		製図 DRN	谷 銅 戸 島
			1998. 3. 9

S16R
 GOVERNOR
 三菱重工業株式会社 汎用機・特車事業本部
 MITSUBISHI HEAVY INDUSTRIES, LTD. GENERAL MACHINERY & SPECIAL VEHICLE HEADQUARTERS.
 図面番号 37896-63005
 DRAWING No. 1/2

旧引
 汎特
 2011
 12.12

FULL-CAD

3 新図 サイズ A 3
 1 旧引図
 2 設計標準品
 3 板金溶接品
 4 組立品
 5 切削品
 6 その他(購入品)

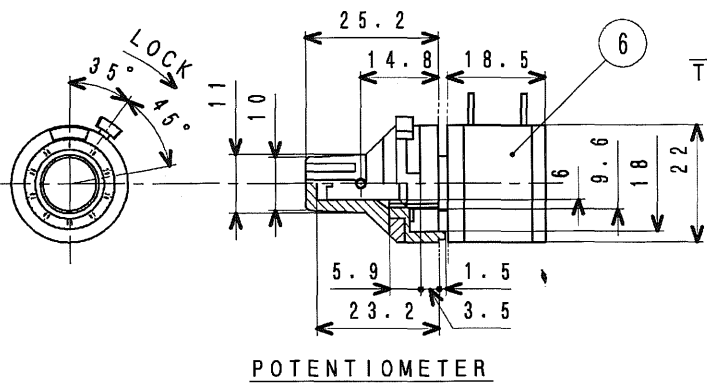

POTENTIOMETER

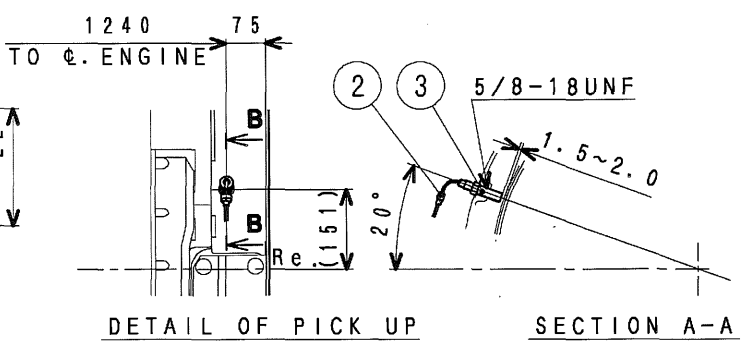

DETAIL OF PICK UP SECTION A-A

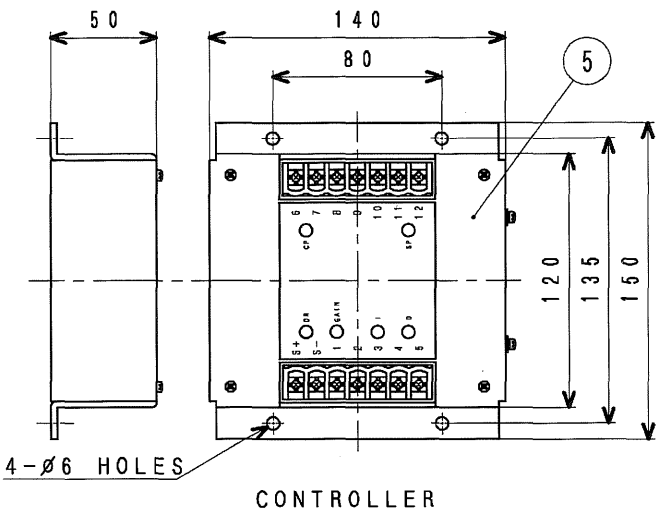

CONTROLLER

NOTE (1) THE ☆ MARKED PARTS ARE LOOSE SUPPLY.

51	F2515-12000	WASHER, SPRING	6
50	F2515-10000	WASHER, SPRING	2
49	F2515-08000	WASHER, SPRING	9
48	F2515-06000	WASHER, SPRING	4
47	08302-06000	WASHER	4
46	F2445-10000	NUT, SELF LOCKING	1
45	F2300-08000	NUT	6
No.	PARTS NO.	PARTS NAME	Q'TY

44	F2300-06000	NUT	4
43	09413-00800	NUT, LOCK	2
42	33063-11400	NUT	3
41	F1035-12065	BOLT	2
40	F1035-12035	BOLT	3
39	F1035-12025	BOLT	1
38	F1035-10040	BOLT	1
37	F1115-08025	BOLT	2
36	F1035-08020	BOLT	1
35	F1035-06050	BOLT	4
34	F2846-06000	PIN, DOWEL	1
33	48000-96600	SEAL	5
32	34461-07700	WIRE, SEAL	5
31	47500-34200	SPACER	4
30	47500-34100	RUBBER	8
29	32561-18300	PLATE, END	1
28	F3202-03200	RING, SNAP	1
27	F3202-03000	RING, SNAP	1
26	F8007-06201	BEARING, BALL	2
25	F8007-06200	BEARING, BALL	2
24	45940-30101	PLATE, CAUTION	1
23	51776-03000	GRIP	1
22	05902-08060	ROD	1
21	05903-00100	ROD	1
20	37761-26800	LINK, L. H.	1
19	35A61-38701	JOINT, BALL (M8-L)	1
18	37563-15401	JOINT, BALL MALE	1
17	35A61-38601	JOINT, BALL (M8-R)	3
16	32561-48600	SPRING	1
15	91365-03200	SPACER	1
14	37761-27100	SHAFT, CONTROL	1
13	47520-31200	LEVER	1
12	47520-34400	LEVER, L. H., B	1
11	37761-37200	LEVER, L. H., A	1
10	37761-27800	LEVER, LINK, L. H	1
9	37761-07600	BRACKET, LEVER, L. H	1
8	47500-39901	COVER	1
7	47520-31101	BRACKET, ACTUATOR	1
☆ 6	04410-33700	POTENTIOMETER	2
☆ 5	04410-33100	CONTROLLER	1
☆ 4	04410-32902	CONNECTOR	1
3	04410-43410	PICK UP	1
☆ 2	04410-43500	CONNECTOR	1
1	04410-32011	ACTUATOR	1
No.	PARTS NO.	PARTS NAME	Q'TY

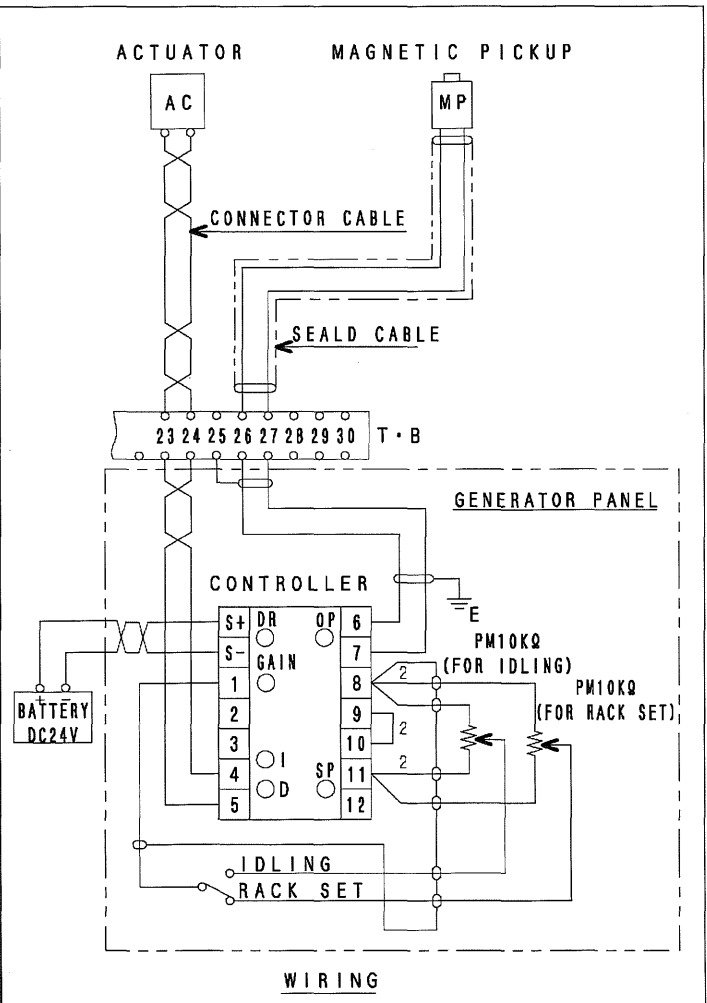

WIRING

MHI CONFIDENTIAL

3rd ANGLE PROJECTION	尺度 SCALE
4590-G659 '11. 3.28 青藤	4590-4983 '99. 2.25 福田
CHG ED-NO DATE CHK	認可 APPD 橋 換図 CHK 竹谷 福田 製図 DRN 谷 銅 戸 島
1998. 3. 9	

S16R GOVERNOR

三菱重工業株式会社 汎用機・特車事業本部
MITSUBISHI HEAVY INDUSTRIES, LTD. GENERAL MACHINERY & SPECIAL VEHICLE HEADQUARTERS.

図面番号 37896-63005 2/2
DRAWING No.

旧引
汎特
2011
12.12

FULL-CAD

3 新図 サイズ
④ 旧引図 A 3
① 組立図 2 鍍銀部用品 3 板金溶接品 4 組立品
5 初刷品 6 その他(購入品)

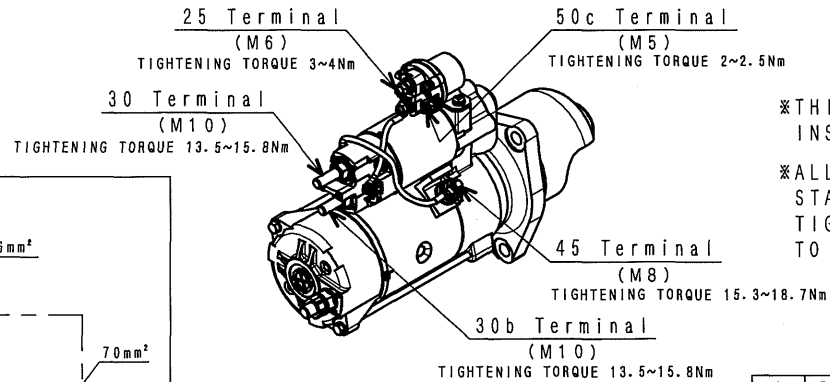
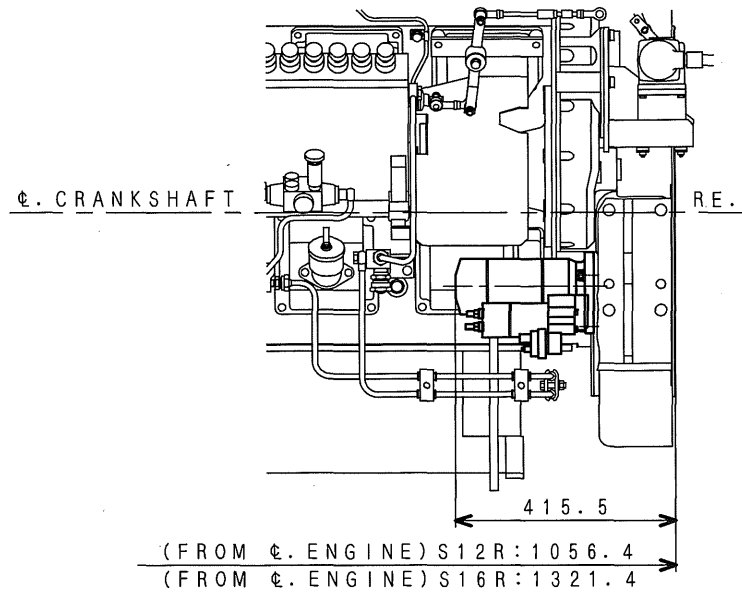
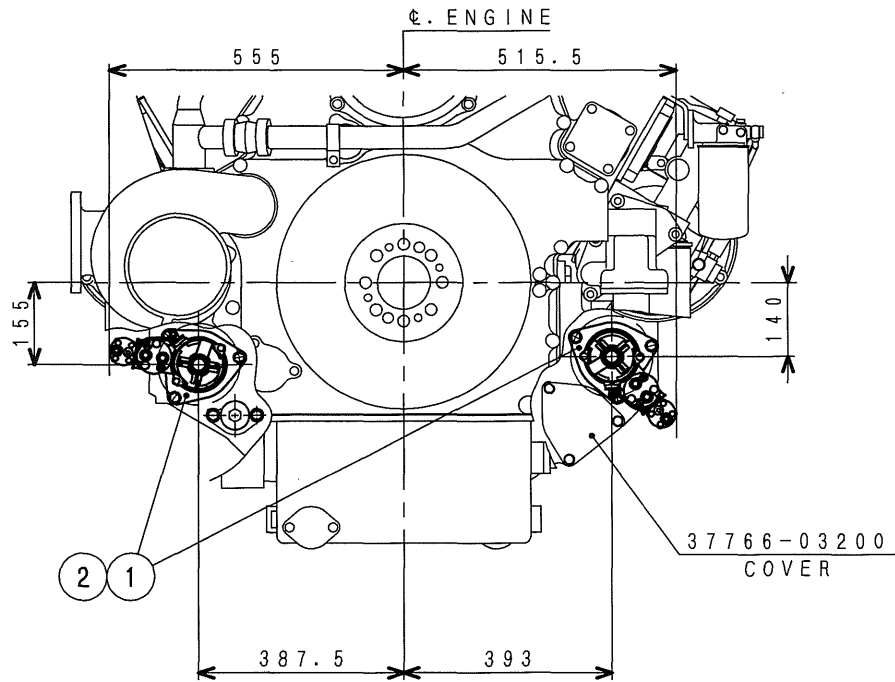

※ THIS VIEW DOES NOT SHOW THE INSTALLATION ATTITUDE.

※ ALL NUTS FOR WIRING BELONG TO STARTER (NO NEED TO PREPARE) TIGHTENING TORQUE SHALL CONFORM TO THE INDICATION ON THIS FIGURE.

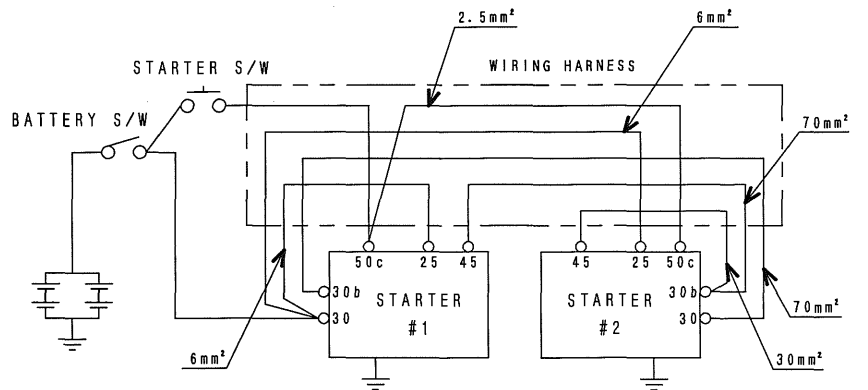

MHI CONFIDENTIAL

2	F1805-12035	BOLT	6
1	38E66-00201	STARTER, 7.5kW, PARA	2
No.	PARTS NO.	PARTS NAME	Q'TY

CHG	EO-NO	DATE	CHK
認可 APPD	橋口	検図 CHK	T. HASEGAWA K. SAKAMOTO
		製図 DRN	N. YAMAGUCHI
			2016. 3. 25

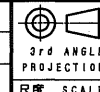

S12R, S16R
STARTING MOTOR

三菱重工業株式会社
MITSUBISHI HEAVY INDUSTRIES, LTD.

図面番号
DRAWING No. 38E96-66051

③ 新図	サイズ A 3	① 組立図	2 鋼線線製品	3 合金溶接品	4 組立品
4 旧引図		5 切削品	6 その他(購入品)		

M/C

S12R: 616
S16R: 881
(FROM ♀. ENGINE)

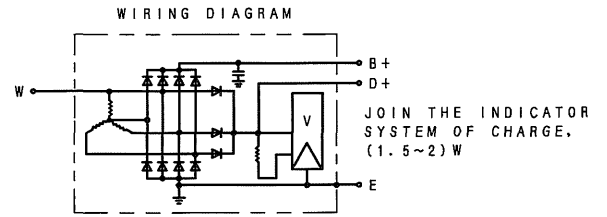
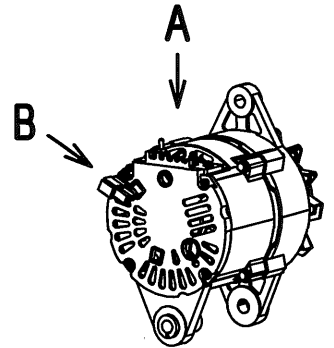
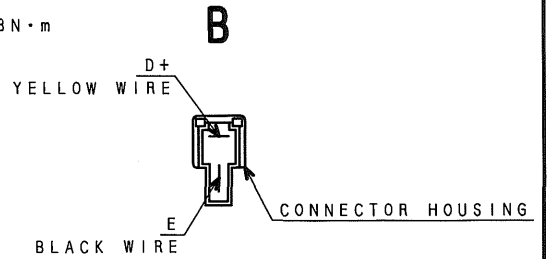
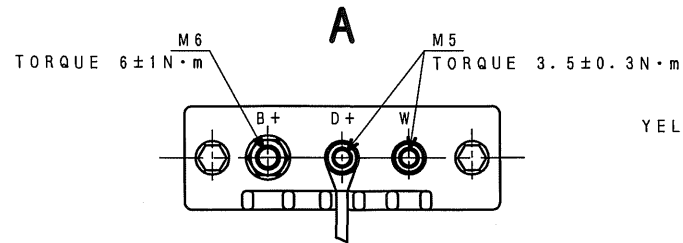
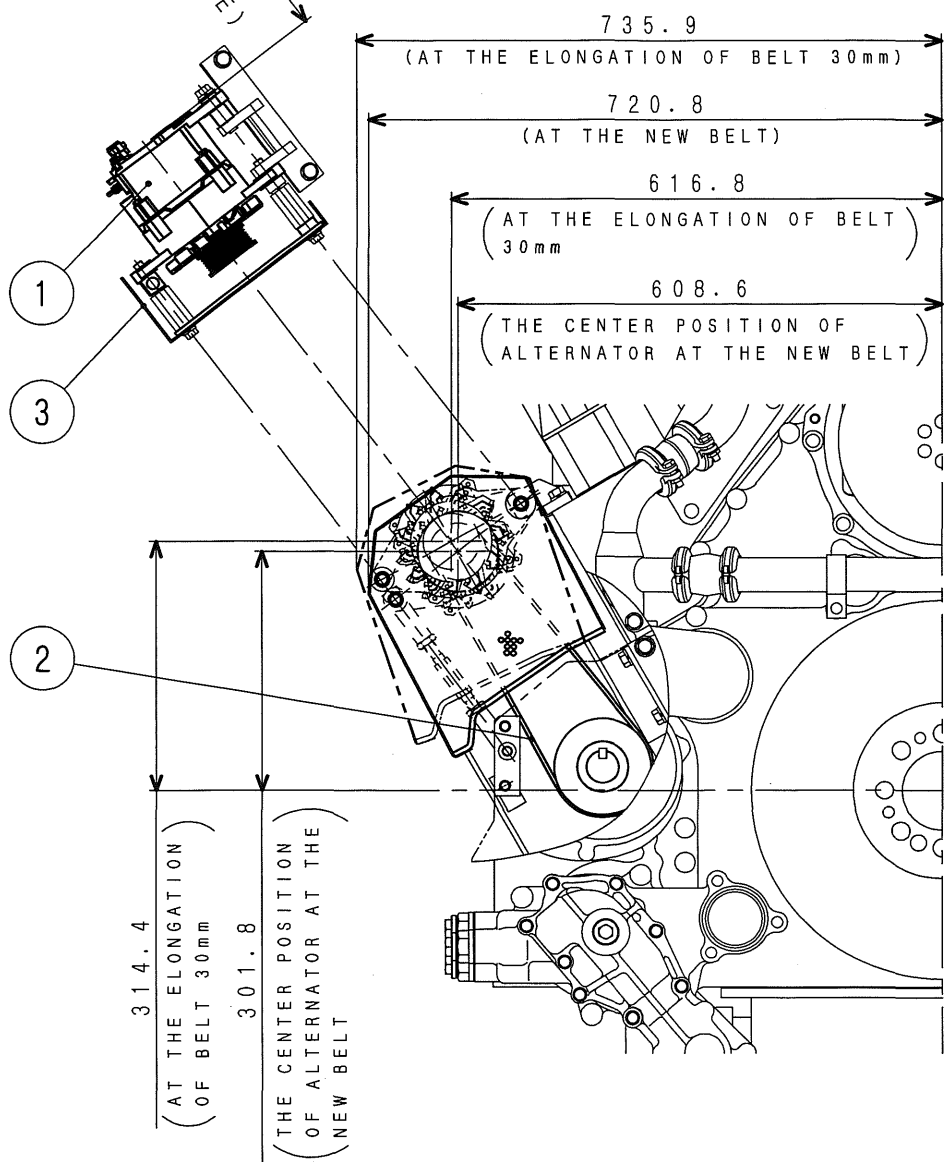

SPECS	28V 55A
PAIRS OF CLAWS	6
WORKING TEMPERATURE	-40°C~105°C
RATED SPEED	6000r/min
MAXIMUM SPEED	12000r/min
STARTING GENERATE SPEED	≤1200r/min (COLD)
POLARITY	CONTINUOUS
VOLTAGE REGULATED VALUE	n=6000r/min I=27.5A U=28.5±0.3V
SPEED CHARACTERISTIC	n=2000~10000r/min I=5.5A ΔU ≤ 0.3V
LOAD CHARACTERISTIC	n=6000r/min I=5.5~49.5A ΔU ≤ 0.5V

VOLTAGE (V)	SPEED (rpm)	COLD STATE	HOT STATE
27	1500	I ≥ 25A	I ≥ 20A
27	2500	I ≥ 40A	I ≥ 35A
27	5000	I ≥ 62A	I ≥ 57A

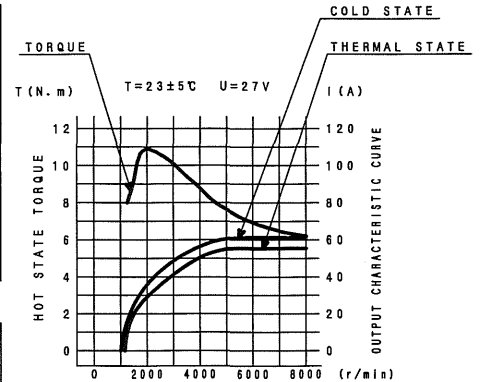

3	38E68-12500	COVER, ALT BELT, KD	1
2	38E68-04400	BELT, RIB 6PK-951	1
1	38C68-18500	DYNAMO, 28V-55A, 6PK	1
No.	PARTS NO.	PARTS NAME	Q'TY

MHI CONFIDENTIAL

CHG	ED-NO	DATE	CHK	3rd ANGLE PROJECTION 尺度 SCALE
認可 APPD	検図 CHK	製図 DRN	T. HASEGAWA K. SAKAMOTO N. YAMAGUCHI 2016. 3. 25	

S12R, S16R
DYNAMO

三菱重工業株式会社
MITSUBISHI HEAVY INDUSTRIES, LTD.

図面番号
DRAWING No. 38E96-68051

③新図 ④旧図 サイズ A 3 ①組立図 ②辦驗機部品 ③板金溶接品 ④組立品 ⑤切別品 ⑥その他(購入品)

M/C

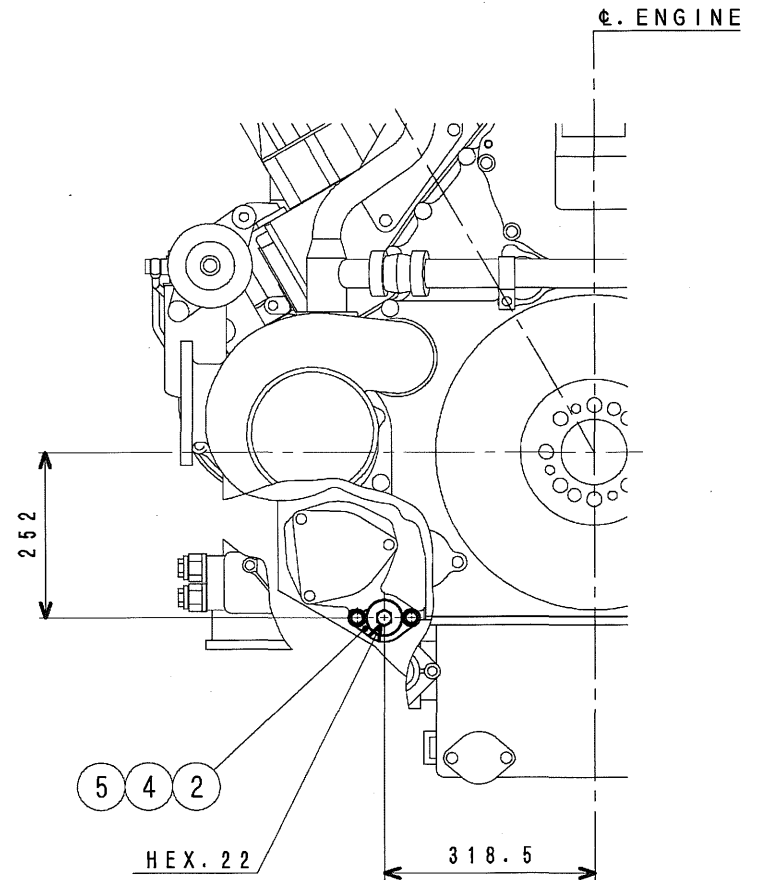
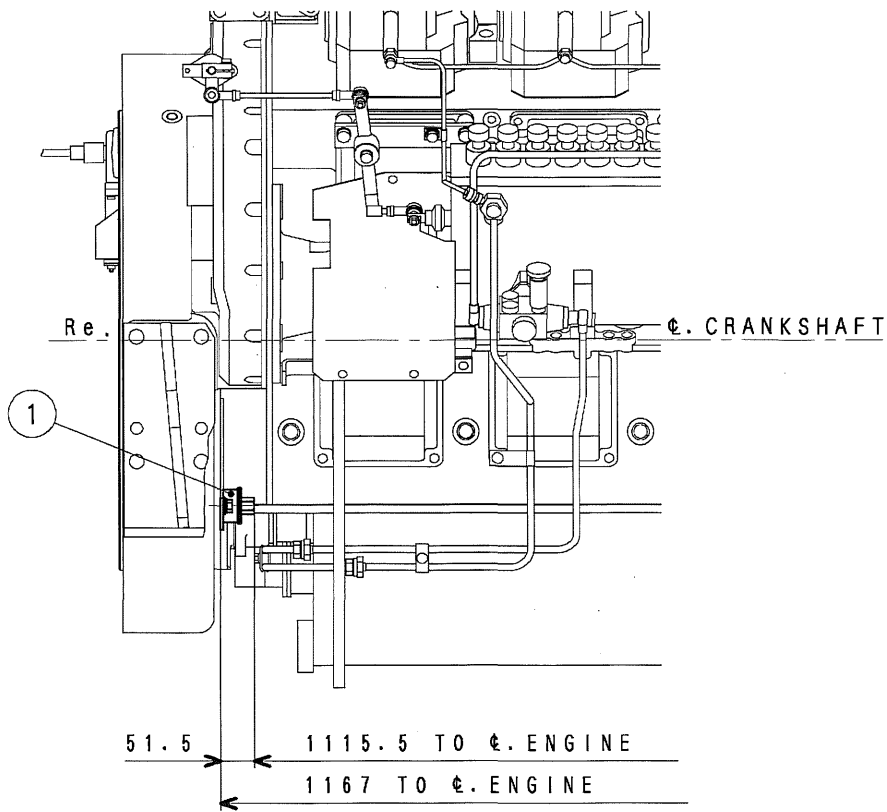

NOTE (1) THE ☆ MARKED PARTS ARE LOOSE SUPPLY.

5	F2500-12000	WASHER, PLAIN	2
4	F1805-12020	BOLT	2
3	37571-01500	PLATE, CAUTION	1
2	37571-10300	FLANGE	1
1	37771-00102	GEAR, TURNING	1
No.	PARTS NO.	PARTS NAME	Q' TY

MHI CONFIDENTIAL

▲					3rd ANGLE PROJECTION 尺度 SCALE
▲					
▲	4590-G661	'11. 3. 29	齊藤		
CHG	ED-NO	DATE	CHK		
認可 APPD	橋	検図 CHK	竹 福	製図 DRN	谷 戸
	口		谷 田		1997. 8. 8

S16R

TURNING DEVICE

三菱重工業株式会社 汎用機・特車事業本部
MITSUBISHI HEAVY INDUSTRIES, LTD. GENERAL MACHINERY & SPECIAL VEHICLE HEADQUARTERS.

図面番号 37896-71001
DRAWING No.

3 新 図 サイズ
④ 旧 引 図 A 3 ① 組 立 図 ② 鑄 造 部 品 ③ 板 金 接 接 品 ④ 組 立 品
⑤ 切 削 品 ⑥ その他 (購 入 品)

旧引
汎特
2011
12.12

FULL-CAD

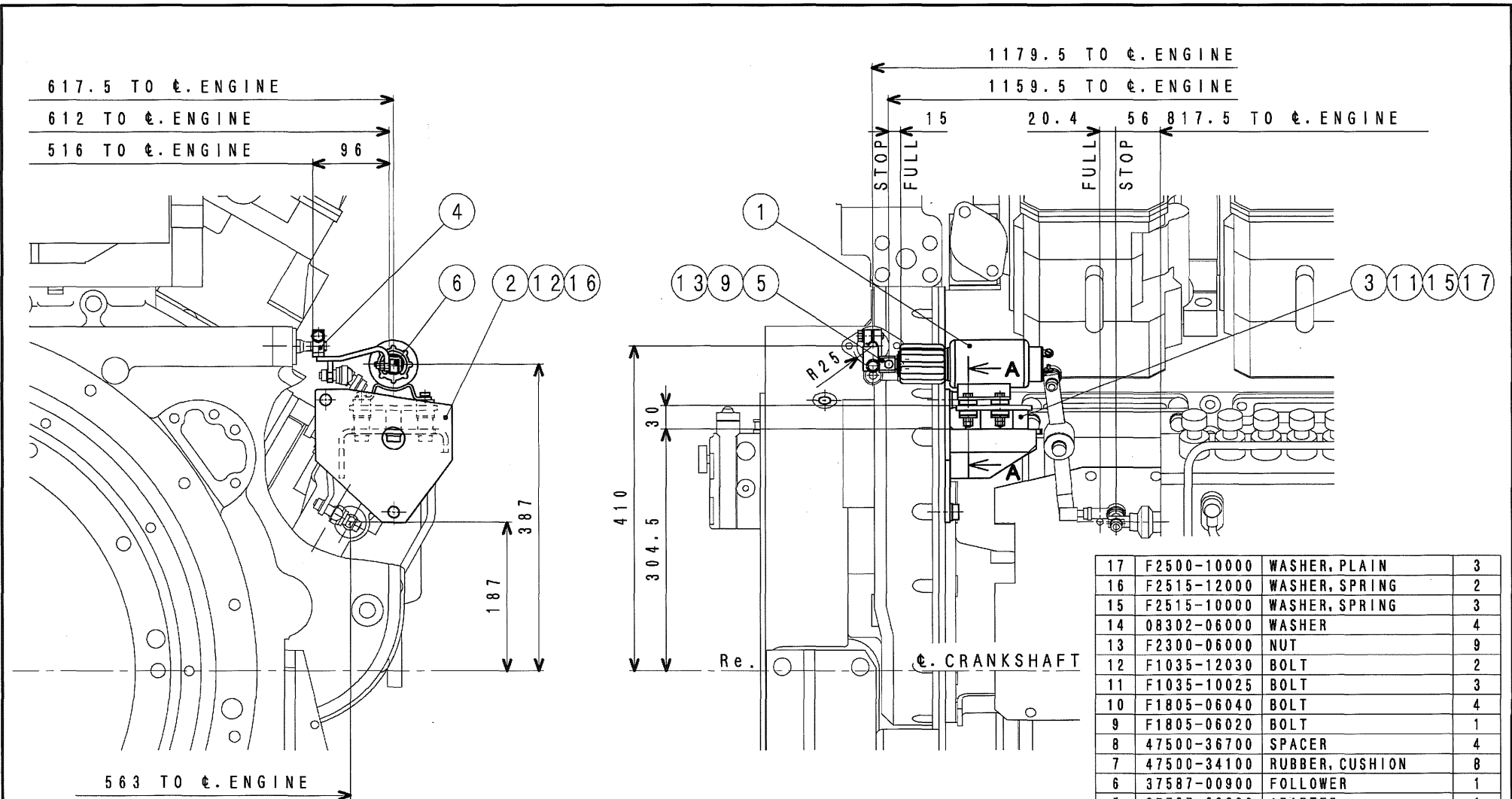

17	F2500-10000	WASHER, PLAIN	3
16	F2515-12000	WASHER, SPRING	2
15	F2515-10000	WASHER, SPRING	3
14	08302-06000	WASHER	4
13	F2300-06000	NUT	9
12	F1035-12030	BOLT	2
11	F1035-10025	BOLT	3
10	F1805-06040	BOLT	4
9	F1805-06020	BOLT	1
8	47500-36700	SPACER	4
7	47500-34100	RUBBER, CUSHION	8
6	37587-00900	FOLLOWER	1
5	37787-03200	ADAPTER	1
4	37761-36902	LEVER, R. H., RUN-ON	1
3	47520-25800	PLATE, SOLENOID	1
2	37787-03300	BRACKET, SOLENOID	1
1	04400-08801	SOLENOID	1
No.	PARTS NO.	PARTS NAME	Q'TY

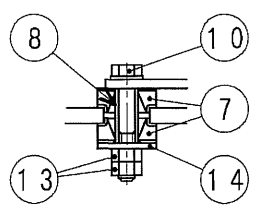

SECTION A-A

MHI CONFIDENTIAL

4	4590-H424	'12.11.19	谷戸
3	4590-G662	'11. 3.28	斉藤
2	4590-D687	'07.10. 4	斉藤
1	4590-7908	'01. 6.20	福田
CHG	ED-NO	DATE	CHK
認可 APPD	橋	換図 CHK	竹 福 谷 田
		製図 DRN	谷 銅 戸 島
		1997.10.31	

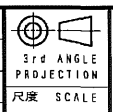

S16R
STOP SOLENOID
三菱重工業株式会社 汎用機・特車事業本部
MITSUBISHI HEAVY INDUSTRIES, LTD. GENERAL MACHINERY & SPECIAL VEHICLE HEADQUARTERS.
図面番号 37896-87502
DRAWING No. 37896-87502

注記 (1) 本図のソレノイドは、シンクロスタート製である。

旧引
汎特
2013
2.8

M/C

3 新図 サイズ
4 旧引図 A 3
1 組立図
2 購買標準品
3 板金溶接品
4 組立品
5 切削品
6 その他(購入品)

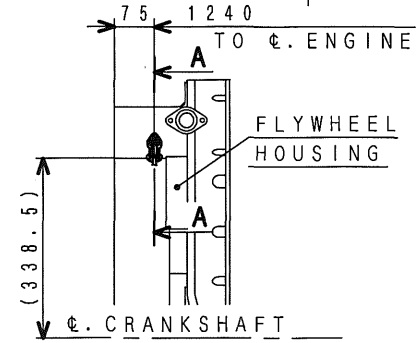
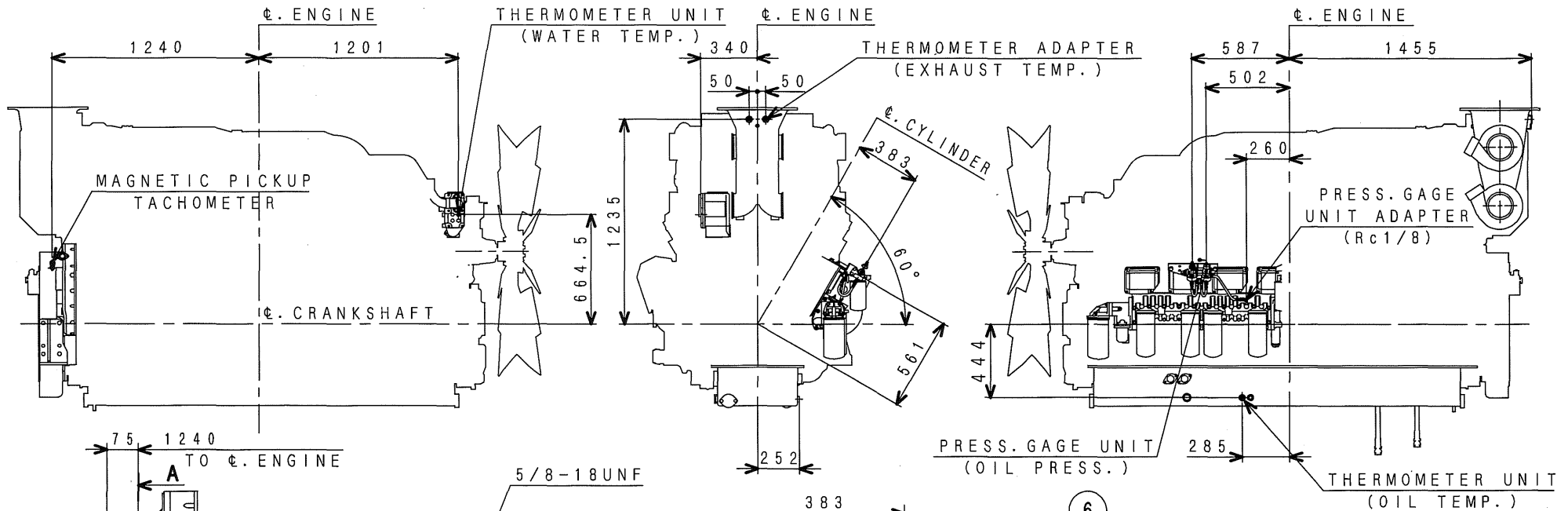

TACHOMETER PICKUP

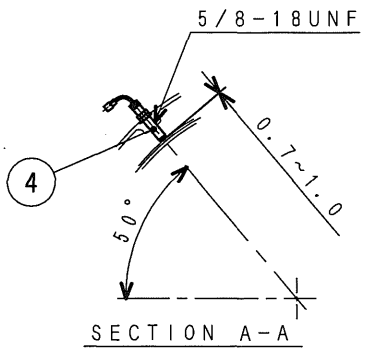

SECTION A-A

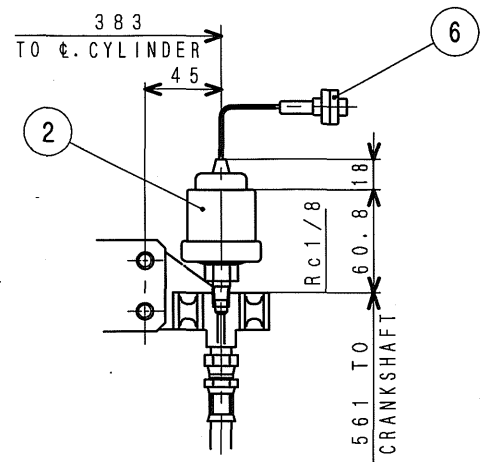

PRESS. GAGE UNIT

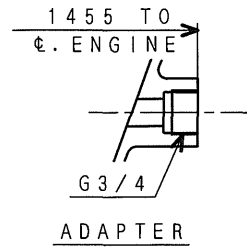

ADAPTER

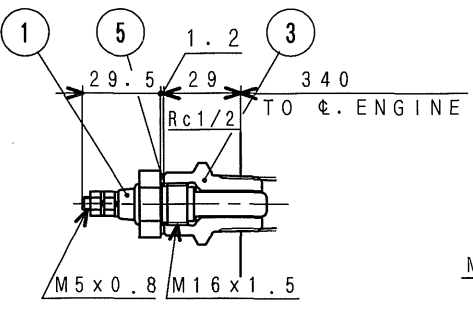

THERMOMETER UNIT
WATER TEMP.

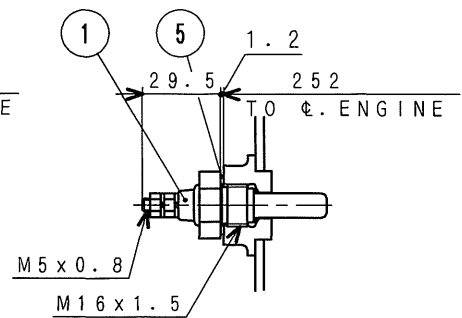

THERMOMETER UNIT
OIL TEMP.

MHI CONFIDENTIAL

NOTE (1) THE ☆ MARKED PARTS ARE LOOSE SUPPLY.

No.	PARTS NO.	PARTS NAME	Q'TY
☆ 6	MH052231	CONNECTOR	1
5	05946-01601	WASHER, SEALING	2
4	04410-43410	PICKUP, MAGNETIC	1
3	45600-42902	CONNECTOR	1
2	04541-86200	UNIT, GAGE	1
1	04524-02230	UNIT, THERMO	2

CHG	EO-NO	DATE	CHK
認可 APPO	接図 CHK	製図 DRN	
	T. HASEGAWA K. SAKAMOTO	N. YAMAGUCHI	2016. 3.25

S16R-PTA, -PTA2
METER & SENSOR
三菱重工業株式会社
MITSUBISHI HEAVY INDUSTRIES, LTD.

図面番号 38F96-90152
DRAWING No. 38F96-90152

① 新図 ② サイズ A 3 ③ 組立品 ④ 旧引図 ⑤ 別部品 ⑥ 5 ⑦ 6 その他(購入品)

W/C

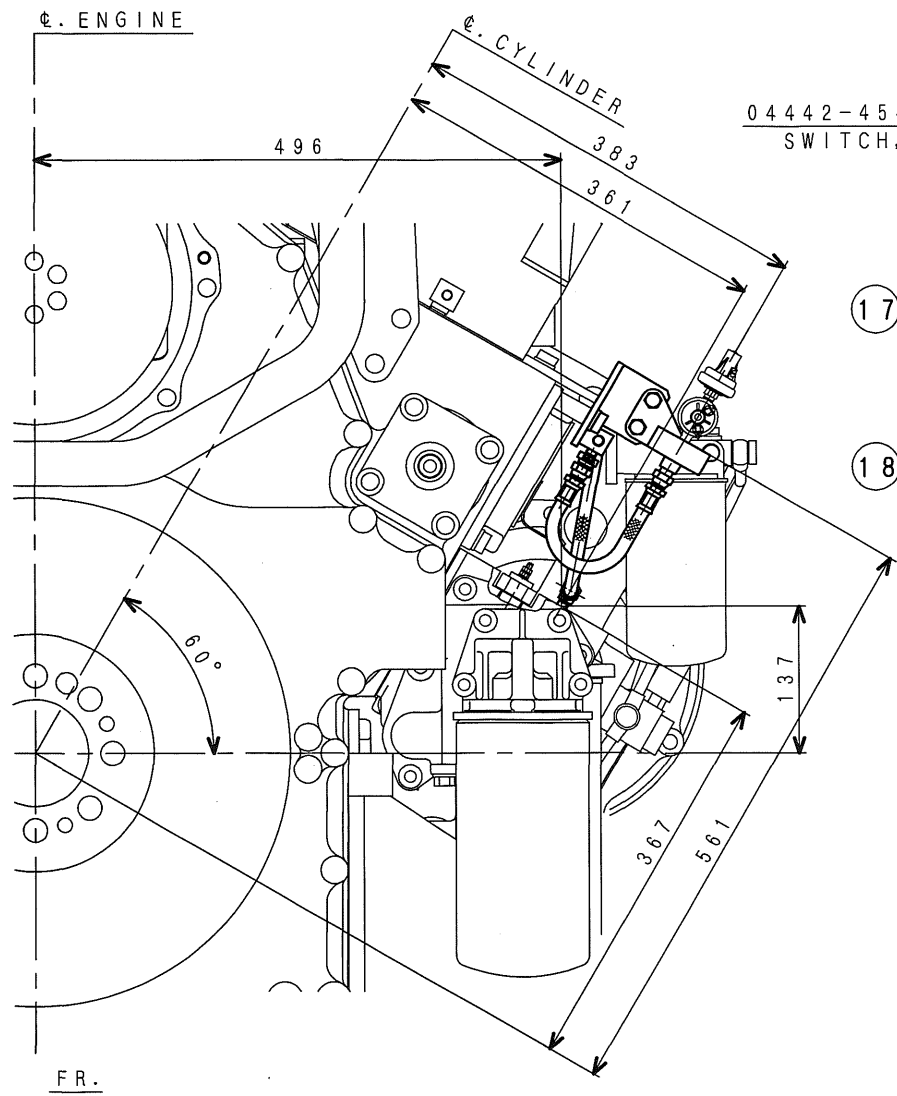

04442-45400 (1.5K)
SWITCH, PRESS.

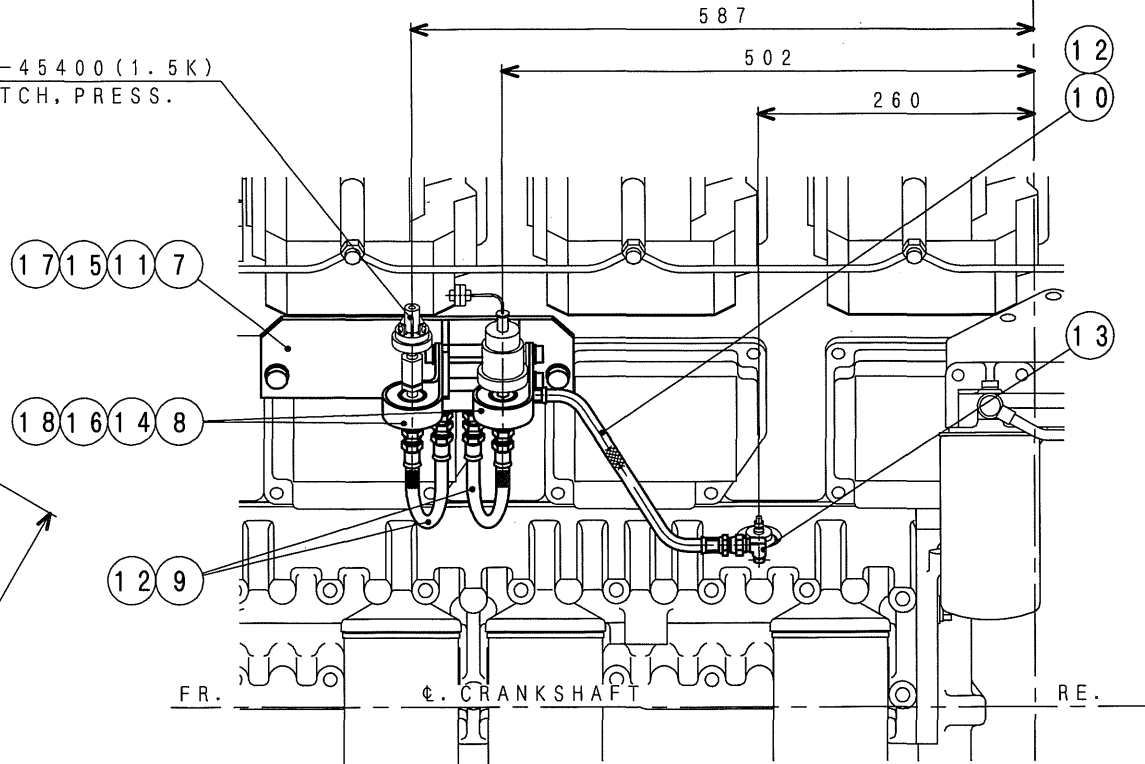

18	F2300-10000	NUT	4
17	F2515-12000	WASHER, SPRING	2
16	F2515-10000	WASHER, SPRING	4
15	F1035-12070	BOLT	2
14	F1035-10025	BOLT	4
13	F4560-06300	ELBOW	1
12	F4540-06300	CONNECTOR	3
11	F5006-10000	PLUG, TAPER	1
10	45951-04028	PIPE, FLEXIBLE	1
9	45951-04024	PIPE, FLEXIBLE	2
8	45644-47900	MOUNT	2
7	47520-40702	BRACKET	1
No.	PARTS NO.	PARTS NAME	Q'TY

MHI CONFIDENTIAL

CHG	EO-NO	DATE	CHK
認可 APPD	検図 CHK	製図 DRN	
	T. HASEGAWA K. SAKAMOTO	N. YAMAGUCHI	2016. 3. 25

S16R-PTA, -PTA2
METER & SENSOR
三菱重工業株式会社
MITSUBISHI HEAVY INDUSTRIES, LTD.

図面番号 38F96-90152
DRAWING No. 2/2

① 新図 ② サイズ ③ 組立図 ④ 2 購買標準品 ⑤ 3 板金溶接品 ⑥ 4 組立品 ⑦ 4 旧引図 ⑧ A 3 ⑨ 5 切削品 ⑩ 6 その他(購入品)

W/C

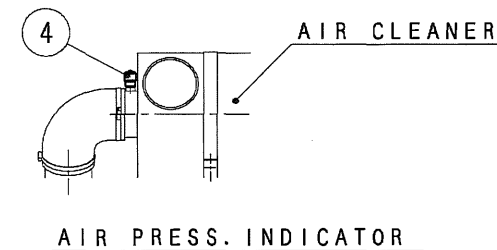
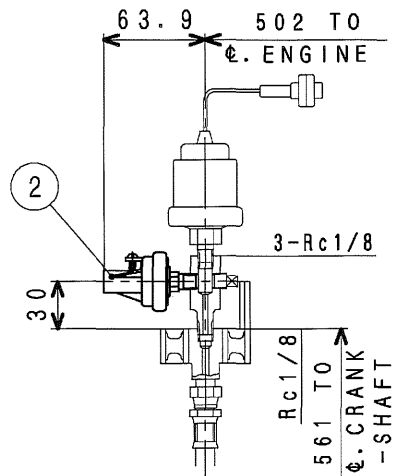
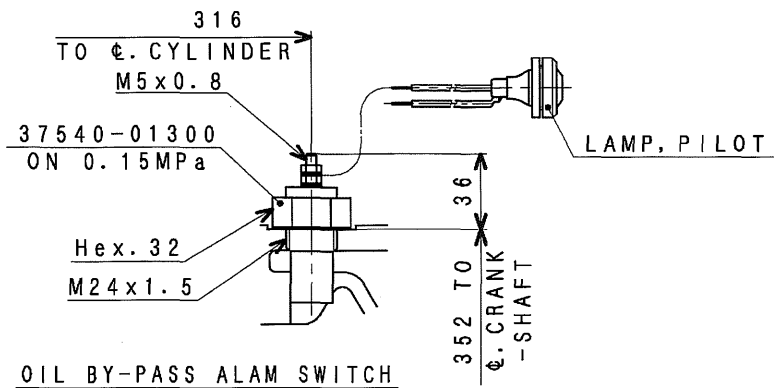
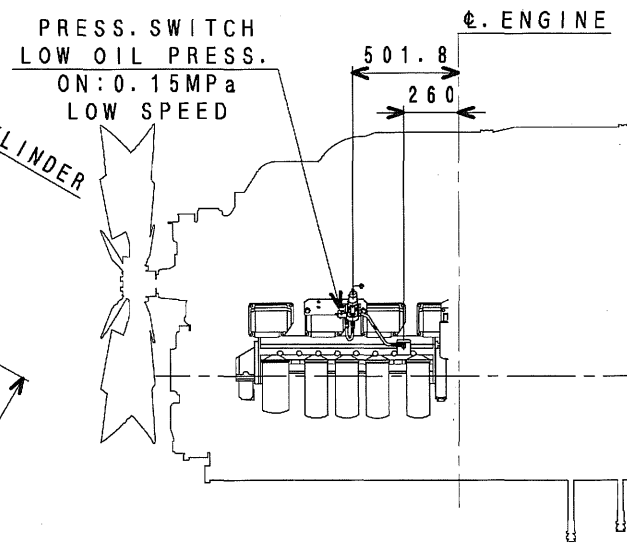
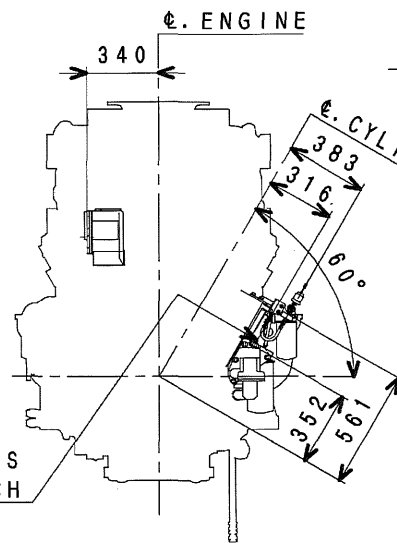
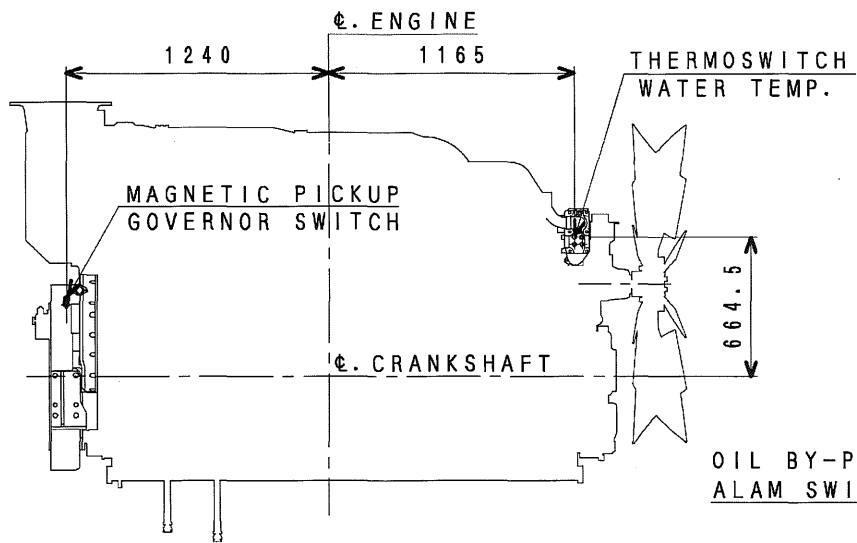

NOTE (1) THE ☆ MARKED PARTS ARE LOOSE SUPPLY.

No.	PARTS NO.	PARTS NAME	Q'TY
☆ 4	47220-34401	INDICATOR 6.2kPa ON	4
3	45600-42902	CONNECTOR	1
2	04442-45400	PRESS. SWITCH 0.15MPa ON	1
1	04442-34500	THERMO SWITCH 98°C ON	1

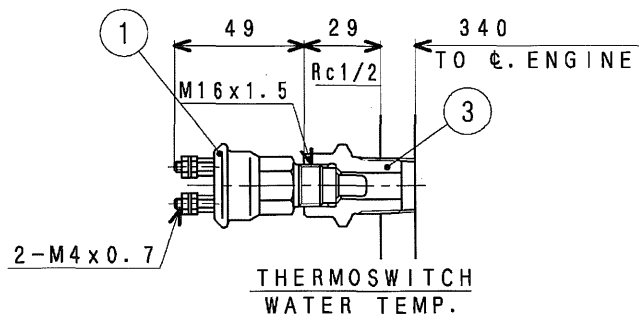

MHI CONFIDENTIAL

3	4590-6664	'11. 3.29	青藤	3rd ANGLE PROJECTION
2	4590-7910	'01. 6.20	福田	尺度 SCALE
1	4590-4698	'98.10.27	福田	
CHG	EO-NO	DATE	CHK	
認可 APPD	橋	検図 CHK	仁 福 尾 田	製図 DRN 青藤
				1998. 8. 20

S16R

ALARM SWITCH

三菱重工業株式会社 汎用機・特車事業本部

MITSUBISHI HEAVY INDUSTRIES, LTD. GENERAL MACHINERY & SPECIAL VEHICLE HEADQUARTERS.

図面番号 37896-90207

DRAWING No.

旧引
汎特
2011
12.12

FULL-CAD

3 新図 サイズ
④ 旧引図 A 3 ① 組立図 2 鋼鋳物部品 3 板金溶接品 4 組立品
5 切削品 6 その他(購入品)

CHECKED BY

WITHDRAWAL SPACE
FOR ELEMENT

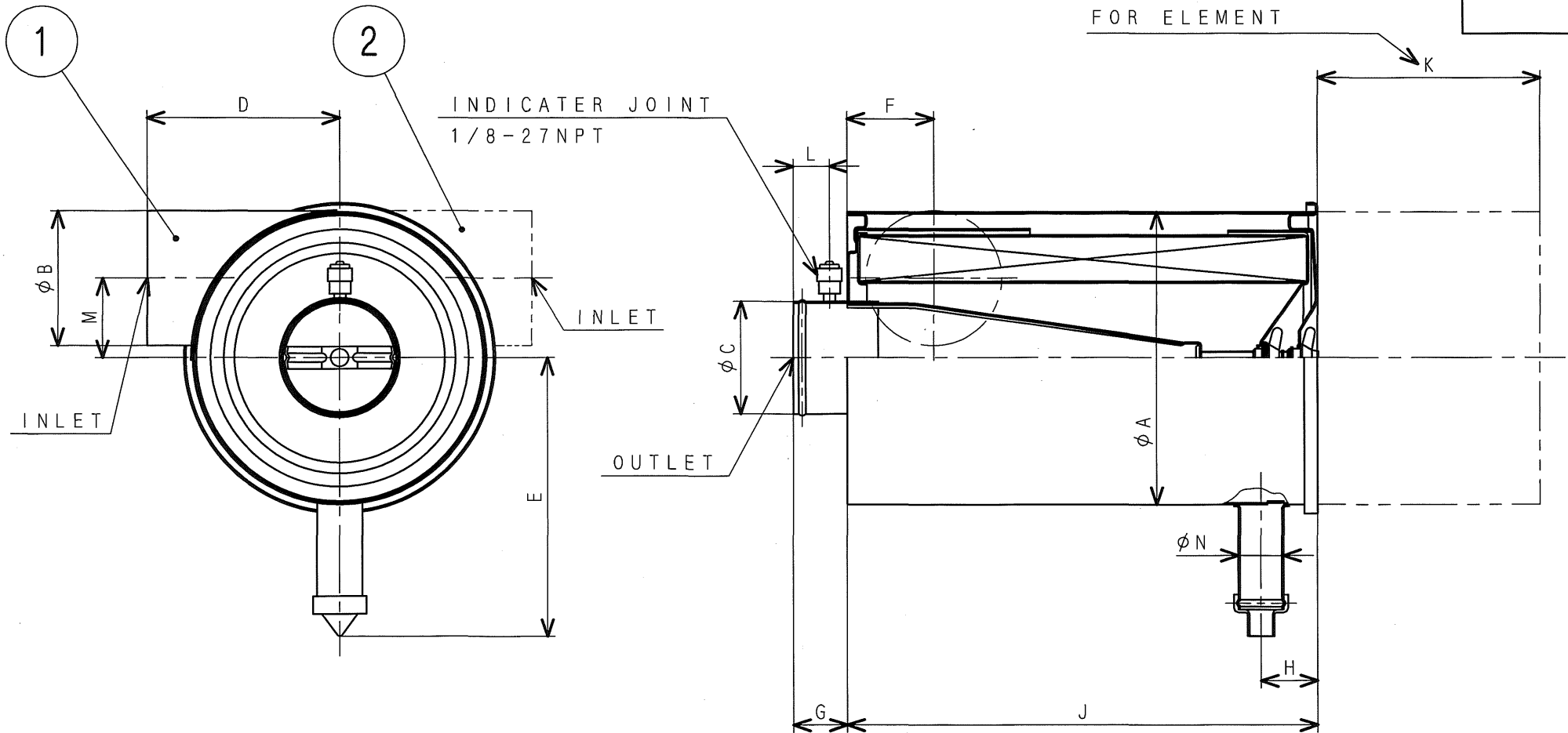

2	38G30-05301		RIGHT	386	177.8	152.4	241.3	283	109.7	60.5	50	629.4	617	40.6	105	48	22.5	38G30-06412
1	38G30-03101		LEFT	386	177.8	152.4	241.3	283	109.7	60.5	50	629.4	617	40.6	105	48	22.5	
NO.	PARTS NO.	TYPE MEASURE	INLET	A	B	C	D	E	F	G	H	J	K	L	M	N	WEIGHT kg	ELEMENT ASSY. PARTS NO.

△	
△	
△	
REV.	DATE

MHI CONFIDENTIAL

AIR CLEANER ASSY.

DWG. NO. S35-5030
MITSUBISHI HEAVY INDUSTRIES, LTD.

CHECKED BY

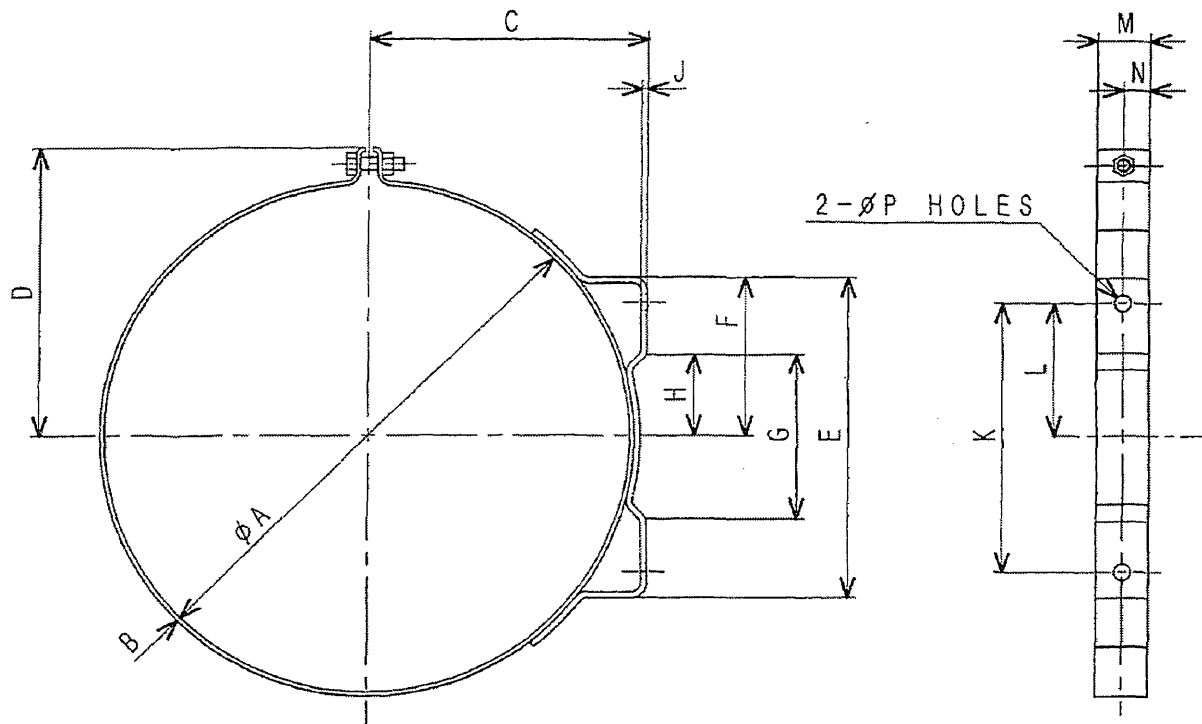

38G30-08301	15" (φ387.0)	387	2.0	201	230	241.4	120.7	/	/	5	203.2	101.6	40	20	2-φ12		
38G30-09301	13" (φ330.2)	330.2	2.0	185.2	200	185	162.5	53.8	26.9	5	152	76	38	18	2-φ10.3		
PARTS NO.	TYPE	MEASURE	A	B	C	D	E	F	G	H	J	K	L	M	N	P	REMARKS

MHI CONFIDENTIAL

REV.	DATE

BAND

DWG. NO. S35-5110
 MITSUBISHI HEAVY INDUSTRIES, LTD.

CHECKED BY

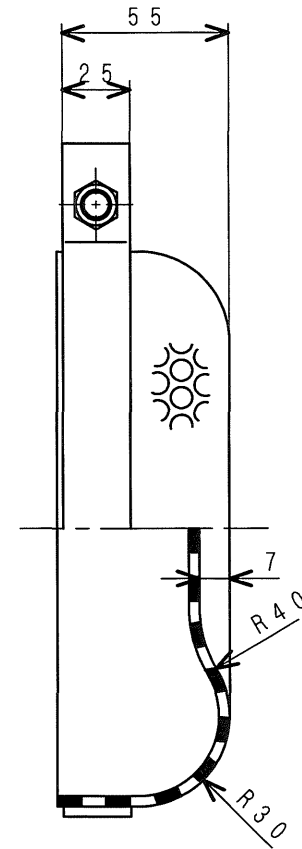
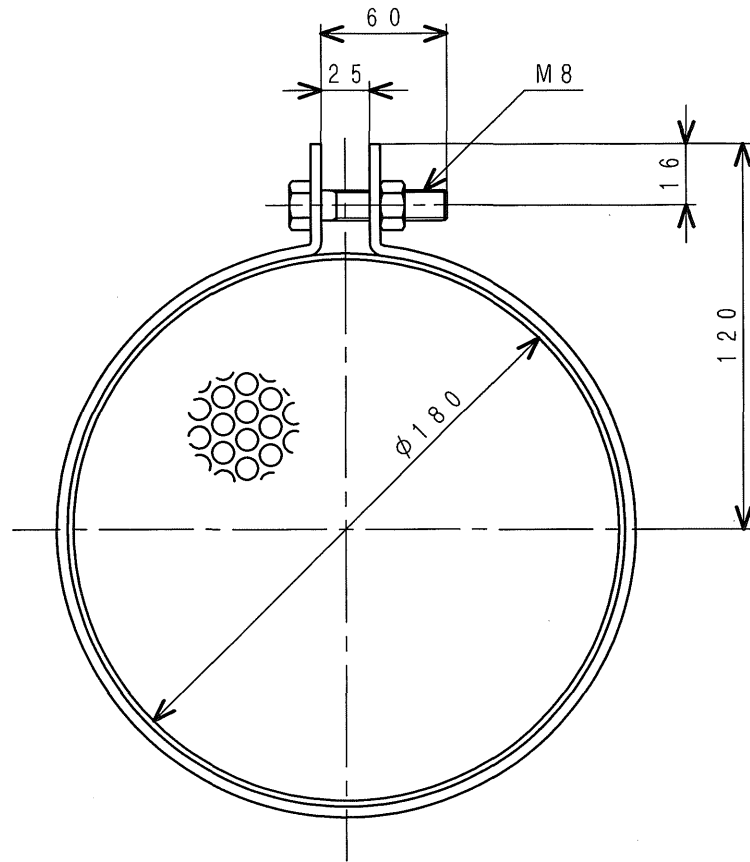

MHI CONFIDENTIAL

△	
△	
△	
△	
REV.	DATE

CAP, INLET
PART NO. 38G30-02201

DWG. NO. S35-5230
MITSUBISHI HEAVY INDUSTRIES, LTD.

CHECKED BY

Y. FUKUDA

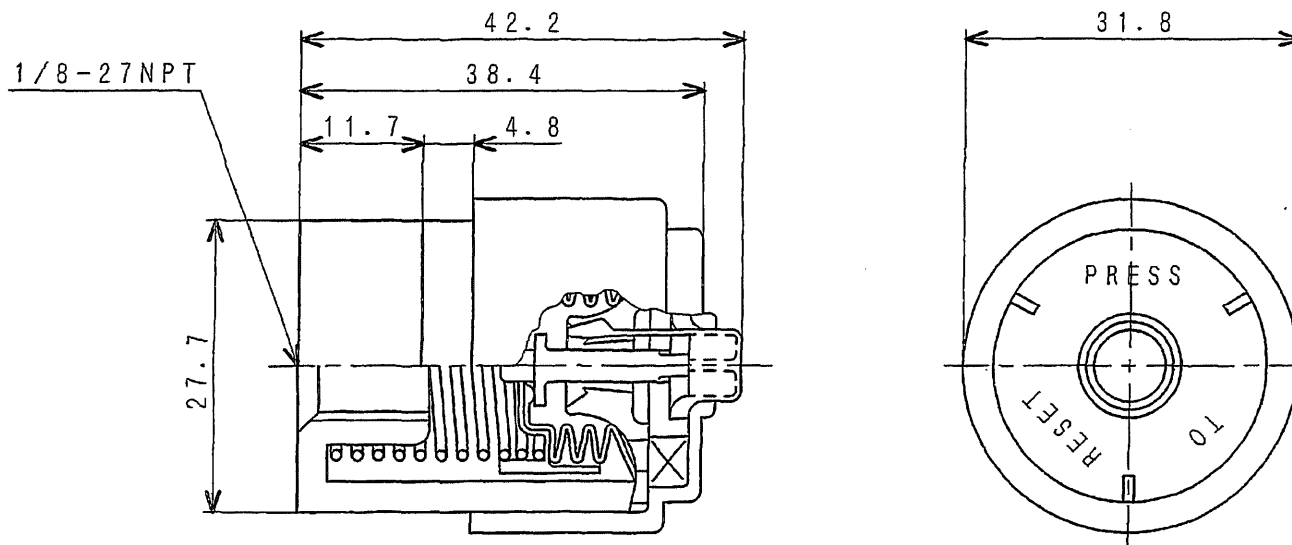

PARTS NO.	RESTRICTION (mmH ₂ O)
47220-30701	762±58
47220-34301	508±48
47220-34401	635±58

MHI CONFIDENTIAL

△	
△	
↑	93 2/18
REV.	DATE

INDICATOR

DWG. NO. S11-0920

 MITSUBISHI HEAVY INDUSTRIES, LTD.
GENERAL MACHINERY & SPECIAL VEHICLE HEADQUARTERS

CHECKED BY
NAKAMURA

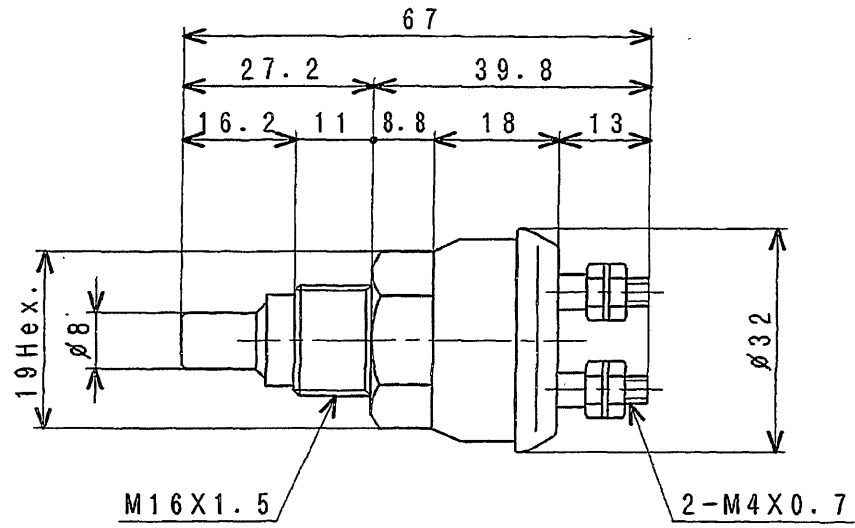

CONNECTING TYPE	PARTS NO.	SET TEMP. (°C)		CONTACTOR CAPACITY	WEIGHT
		ON	OFF		
NO (A-CONTACT)	04442-34300	92±2	85±2	DC24V 0.05A~3A DC100V 0.05A~0.4A AC100V 0.05A~1A	60g
NO (A-CONTACT)	04442-34400	95±2	88±2		
NO (A-CONTACT)	04442-34500	98±2	91±2		
NO (A-CONTACT)	04442-34600	110±2	103±2		
NO (A-CONTACT)	04442-34700	105±2	98±2		
NO (A-CONTACT)	04442-34800	101±2	94±2		
NO (A-CONTACT)	04442-34900	88±2	81±2		
NO (A-CONTACT)	04442-38700	115±2	108±2		
NO (A-CONTACT)	37547-04100	101 ⁰ ₋₂	94±2		

MHI CONFIDENTIAL

6	'00.4.26
8	'08.6.5
7	'06.3.17
REV.	DATE

THERMO SWITCH

DWG. NO. S11-0551
 MITSUBISHI HEAVY INDUSTRIES, LTD.
 GENERAL MACHINERY & SPECIAL VEHICLE HEADQUARTERS

CHECKED BY
K. YATO

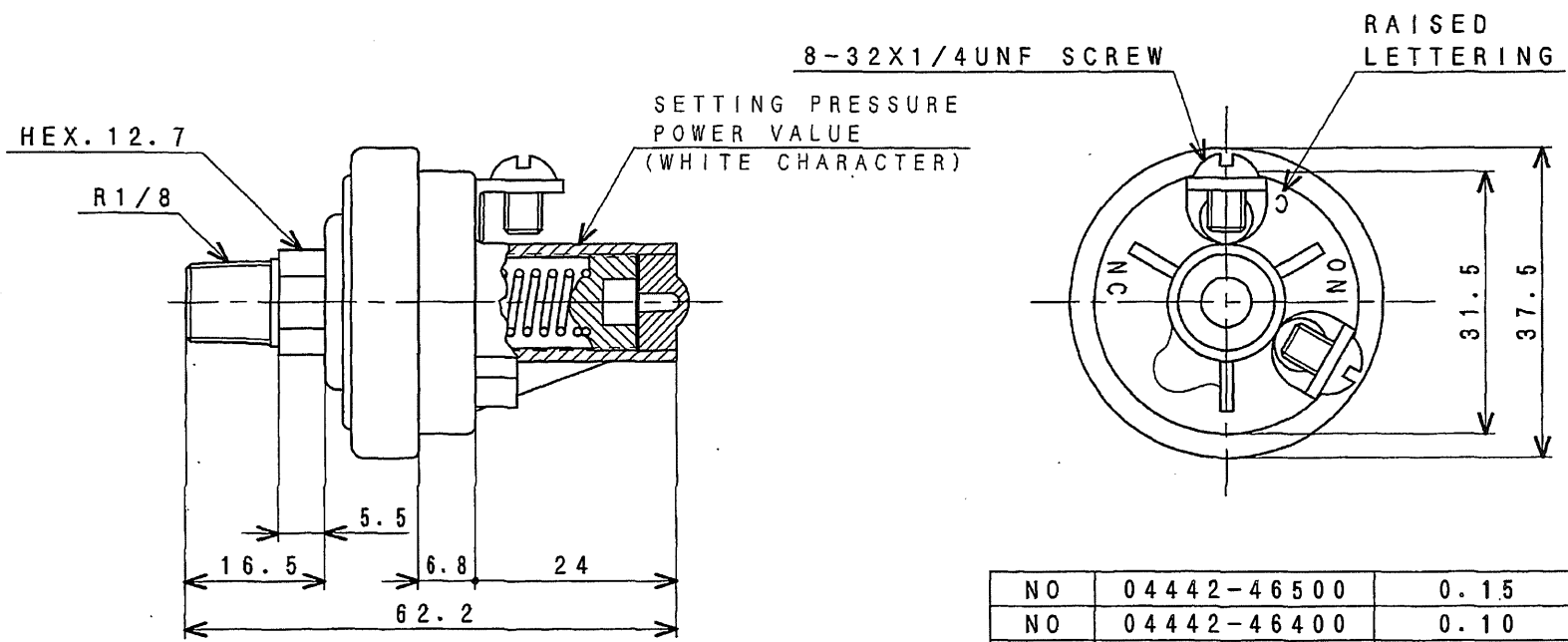

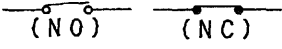
- 5. ON-OFF DIFFERRECE : WITHIN 5%
- 4. POINT OF CONTACT :  (NO) (NC)
- 3. USE TEMP. : -40.0°C~+120.0°C
- 2. RARING : 12VDC-8AMP, 24VDC-4AMP,
120VAC-1AMP, 240VAC-0.5AMP

仕 様 1. MAXIMUM PERMISSIBLE WORKING PRESSURE
: 1.05MPa (SETTING PRESS. : 0.007~0.17MPa)
: 1.75MPa (SETTING PRESS. : 0.18~1.05MPa)

NO	04442-46500	0.15	±0.0075
NO	04442-46400	0.10	±0.005
NO	04442-46300	0.05	±0.0025
NC	04442-46100	6.2KPa	±0.31KPa
NC	04442-45900	0.40	±0.02
NC	04442-45800	0.35	±0.0175
NC	04442-45700	0.30	±0.015
NC	04442-45600	0.25	±0.0125
NC	04442-45500	0.22	±0.011
NC	04442-45400	0.15	±0.0075
NC	04442-45300	0.10	±0.005
NC	04442-45200	0.05	±0.0025
NC	04442-45100	0.03	±0.0015
接点形式	PARTS NO.	ON	ALLOWANCE
		SET PRESS. MPa	

MHI CONFIDENTIAL

3	'11.10.28
2	'08.6.5
1	'06.3.17
REV.	DATE

SWITCH, PRESS

DWG. NO. S.11-0796
 MITSUBISHI HEAVY INDUSTRIES, LTD.
 GENERAL MACHINERY & SPECIAL VEHICLE HEADQUARTERS

CHECKED BY

中村

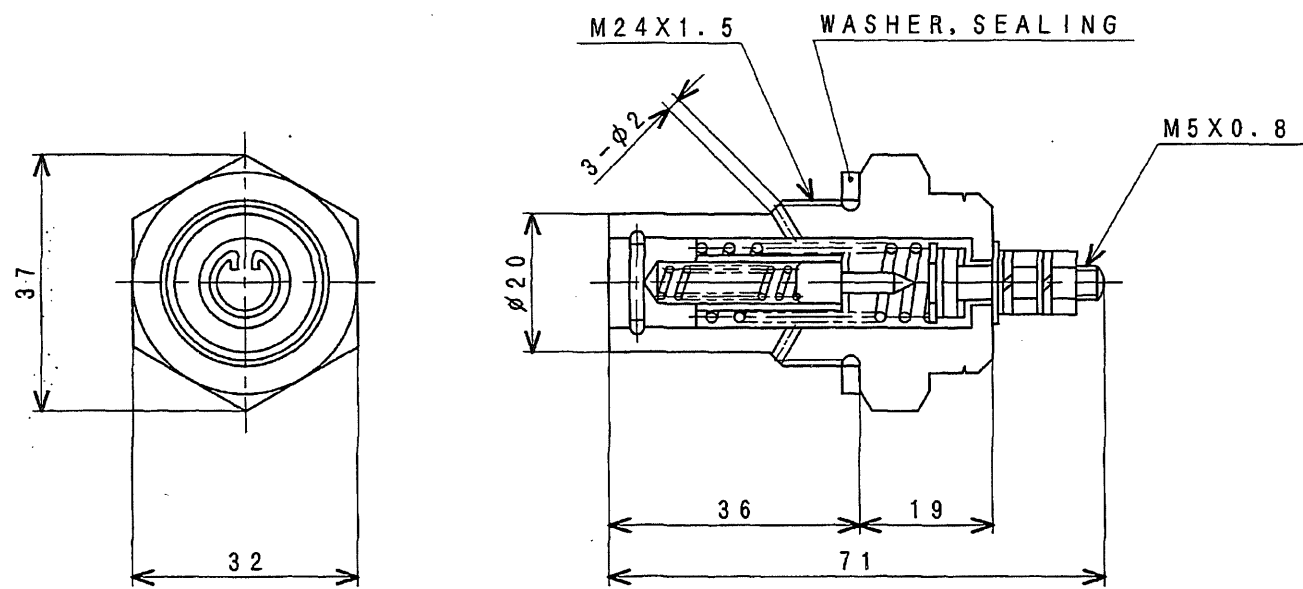

注記 (1) 本図は、部番37540-01300に対し表面処理を変更したものの。
3価クロメート処理 ← 6価クロメート処理

SET PRESS. 0.15MPa

MHI CONFIDENTIAL

△	
△	
△	
REV.	DATE

ALARM, OIL FILTER
PART NO. 37540-01301

DWG. NO. S11-1371
MITSUBISHI HEAVY INDUSTRIES, LTD.
GENERAL MACHINERY & SPECIAL VEHICLE HEADQUARTERS

CHECKED BY
Y. FUKUDA

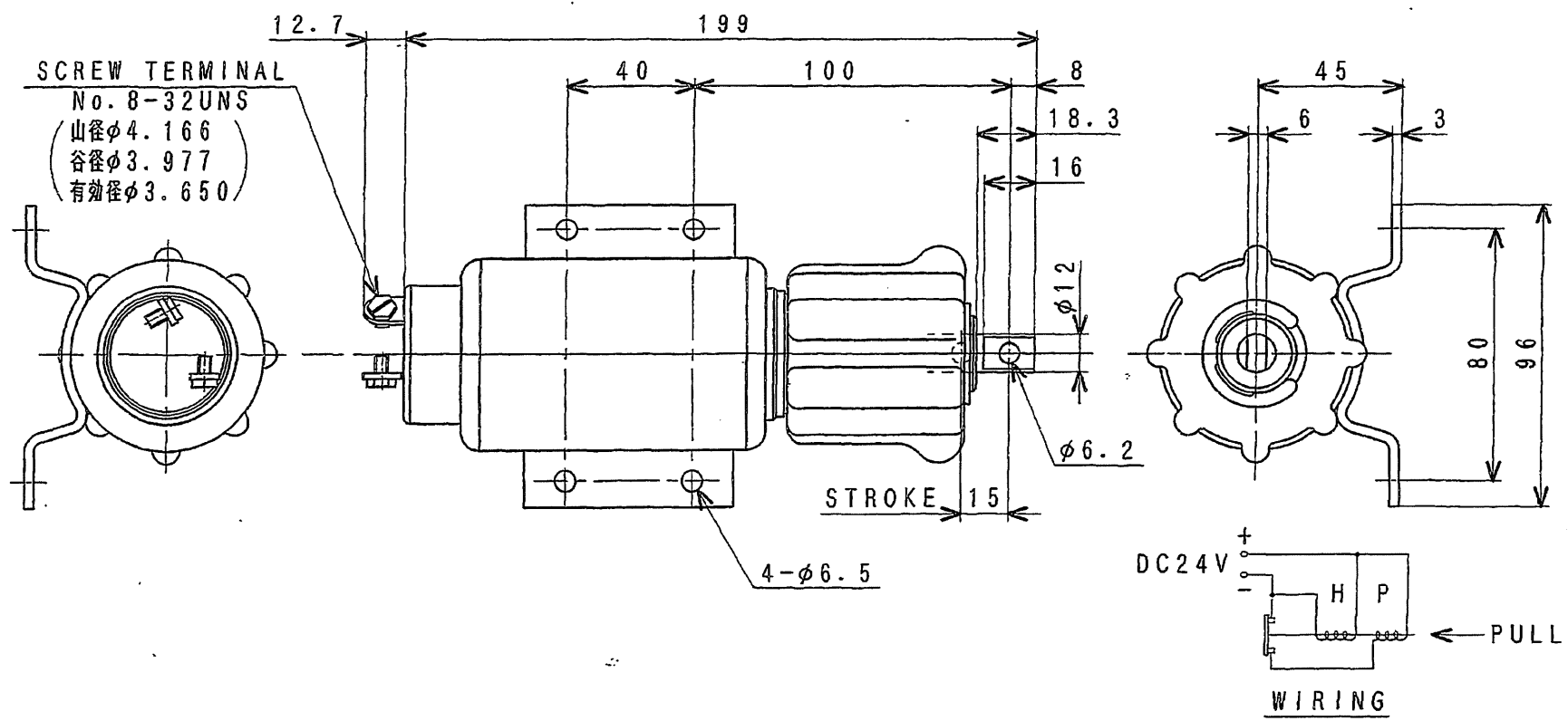

注記 本部品は04400-08800及び04400-08900
に対し下記が異なる。

1. 保持コイルリードワイヤー取出部に太いサイズの皮膜付
リードワイヤーを溶接接続したものである。
2. 吸引、保持コイル切換えスイッチの固定コンタクトの
曲げを平に変更したものである。

04400-08901	0.2 MPa
04400-08801	1.0 MPa
PARTS NO.	RETURN SPRING PRESS.

SPECIFICATION	
VOLTAGE	DC24V
CURRENT	PULL 30.7A, HOLD 0.58A
RATED TIME	CONTINUOUS

MHI CONFIDENTIAL

△	
△	
△	
REV.	DATE

SOLENOID

DWG. NO. S13-0282
MITSUBISHI HEAVY INDUSTRIES, LTD.
GENERAL MACHINERY & SPECIAL VEHICLE HEADQUARTERS

CHECKED BY

Y. FUKUDA

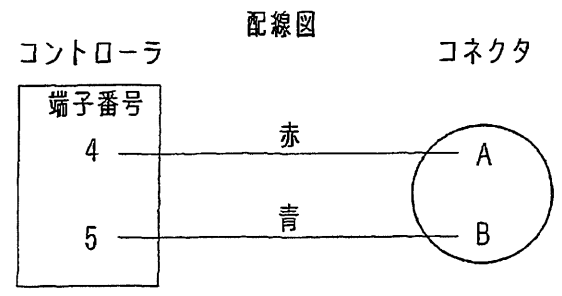
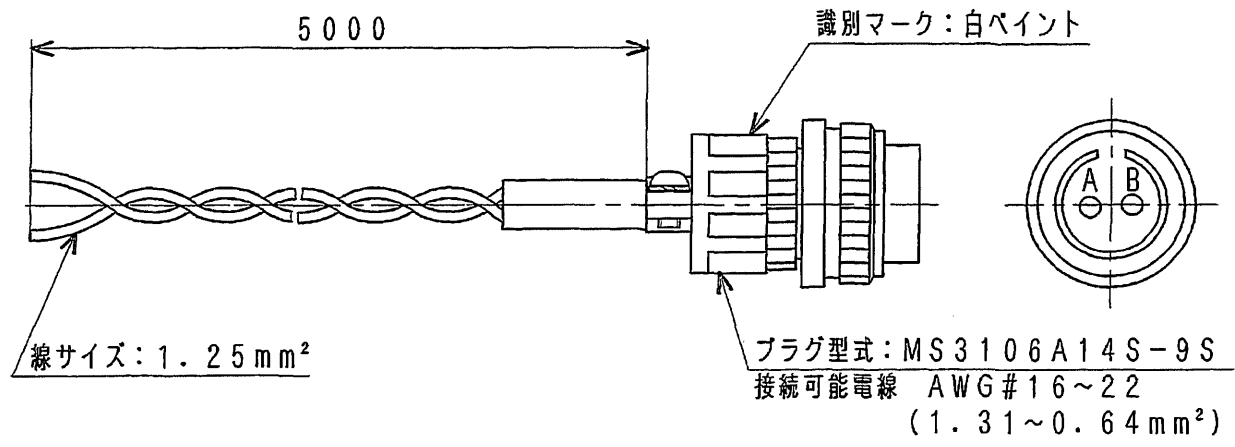

備考 使用先: コントローラ~アクチュエータ間の配線用部品として使用するツイストペアケーブルである。

MHI CONFIDENTIAL

REV.	DATE

CONNECTOR
PART NO. 04410-32902

DWG. NO. S13-1022
MITSUBISHI HEAVY INDUSTRIES, LTD.
GENERAL MACHINERY & SPECIAL VEHICLE HEADQUARTERS

CHECKED BY
Y. FUKUDA

ACTUATOR
04410-32011
04410-37081 (S12H)

MAGNETIC PICKUP
04410-43410

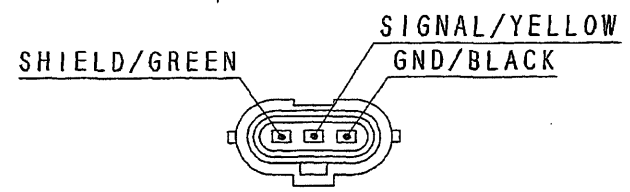
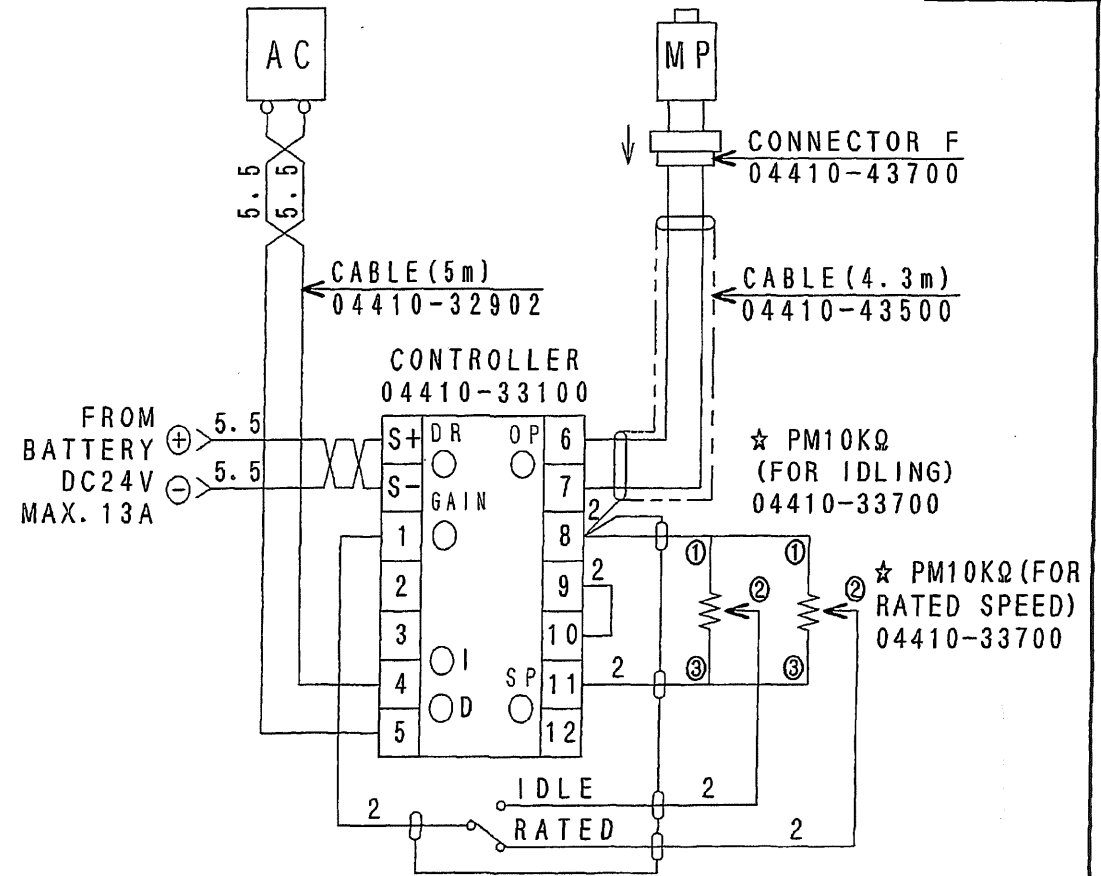
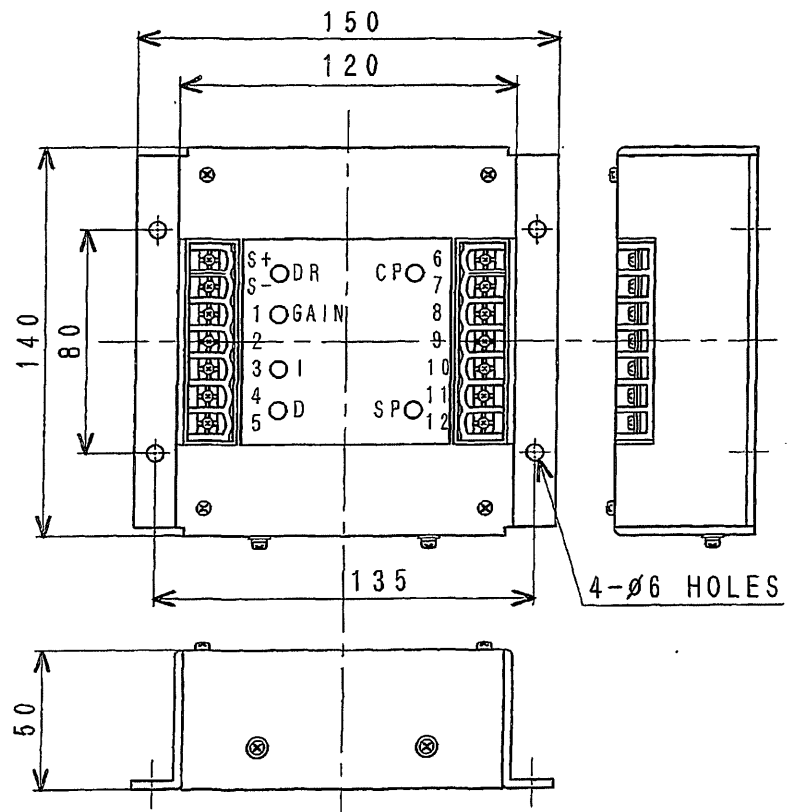

CONNECTOR F
04410-43700

★ MODE CHANGEOVER CONTACTOR
(SHALL BE USE GOLD PLATING CONTACTOR)

WIRING

MHI CONFIDENTIAL

2	'11.4.20
1	'01.6.29
REV.	DATE

CONTROLLER SPEED
PART NO. 04410-33100

DWG. NO. S13-1042
MITSUBISHI HEAVY INDUSTRIES, LTD.
GENERAL MACHINERY & SPECIAL VEHICLE HEADQUARTERS

CHECKED BY
Y. FUKUDA

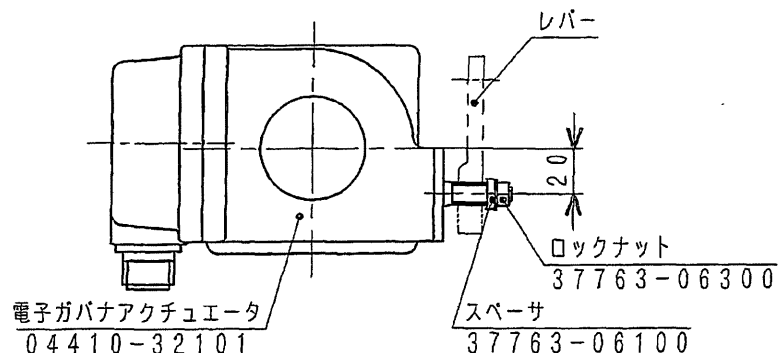

コネクタ用レセプタクル
(キャノンプラグ)

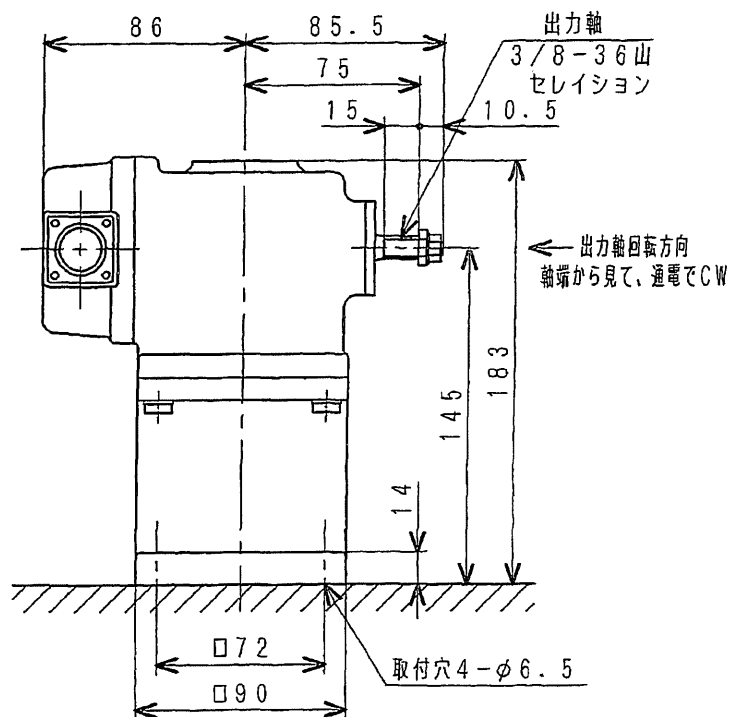
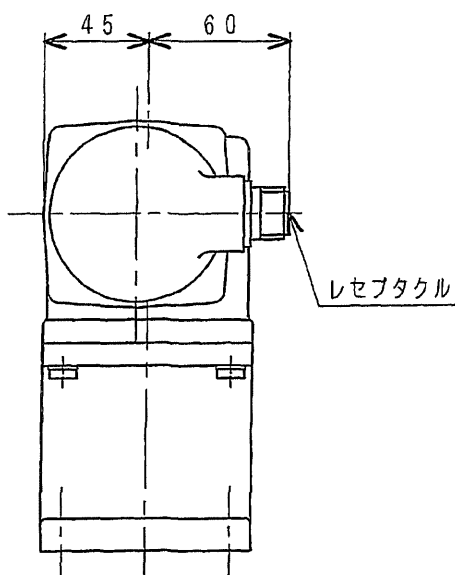
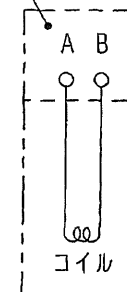

仕様

回転角度	: MAX 40°
トルク	: 0.17 kgf·m 起動時
	起動時常温 8A にて
電源	: DC 24V パルス
起動最低電圧	: DC 16V 50% ed 以下
電流	: MAX 1.3A
常用電流	: 軽負荷制御時 0.5A ~ 2A
周囲温度	: -30°C ~ 100°C
耐震	: 25G JIS D 1601
重量	: 4.7 kgf

MHI CONFIDENTIAL

(2) 本部品は、部番 04410-32010 に対し出力軸の材料を変更したものである。

注記 (1) 本部品は、2線式アクチュエータである。

REV.	DATE

ACTUATOR/SG4017BR
PART NO. 04410-32011

DWG. NO. S13-1761

MITSUBISHI HEAVY INDUSTRIES, LTD.
GENERAL MACHINERY & SPECIAL VEHICLE HEADQUARTERS

CHECKED BY
T. HASHIGUCHI

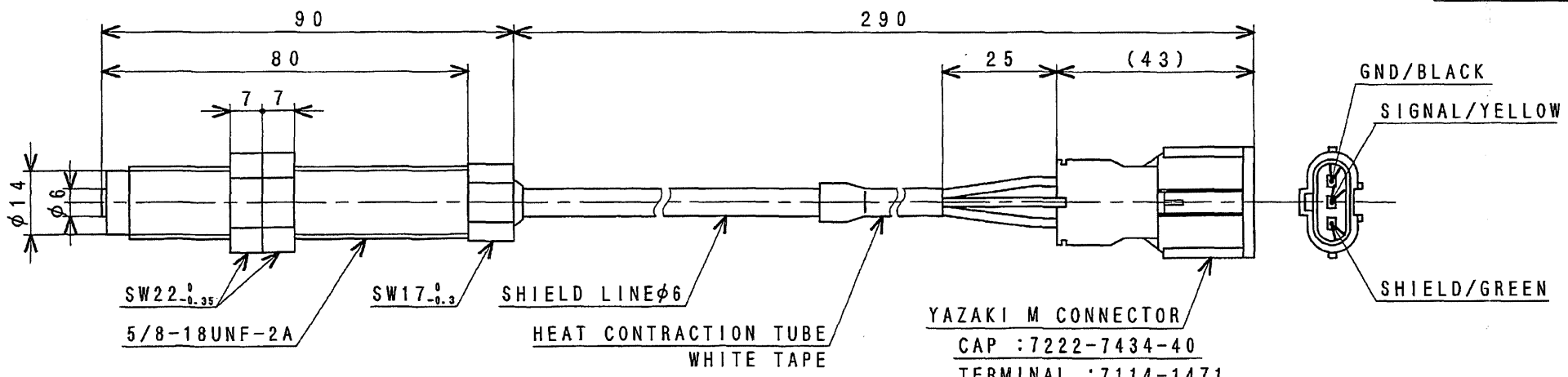

YAZAKI M CONNECTOR
CAP : 7222-7434-40
TERMINAL : 7114-1471
RUBBER PLUG : 7157-7812
REAR HOLDER : 7157-7814-80

SPECIFICATION

1. ELECTRIC MACHINE CHARACTERISTIC
 - OUTPUT VOLTAGE : FIGURE 1. MEASUREMENT CONDITION
 - 4.0Vp-p MORE (at 700Hz)
 - 7.0Vp-p MORE (at 6700Hz)
 - DIRECT CURRENT RESISTANCE : 1.3kΩ~1.6kΩ (at +25°C)
 - INSULATION RESISTANCE : 1MΩ± at DC 500V
(CONNECTOR TERMINAL-HOUSING)
 - ELECTRIC STRENGTH : 50/60Hz AC 500V 1MINUTE
(CONNECTOR TERMINAL-HOUSING)
2. MECHANICAL CHARACTERISTIC
 - CONNECTOR PULL OMISSION POWER : 49N MORE
 - TIGHTENING DESTRUCTION TORQUE : 49N·m MORE
3. OPERATING TEMPERATURE LIMIT
 - 40°C~+120°C

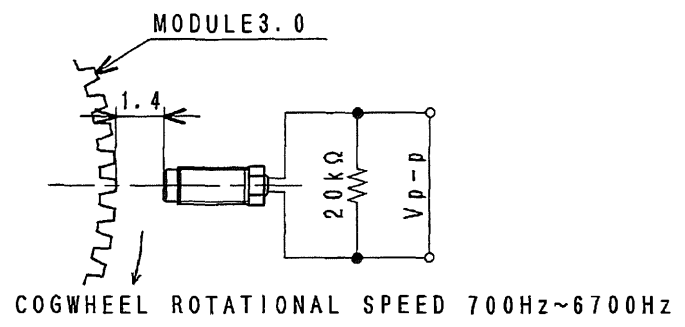

FIGURE 1. OUTPUT CONDITION

MHI CONFIDENTIAL

△	
2	'11.10.28
1	'06.6.9
REV.	DATE

PICKUP, MAGNETIC
PART NO. 04410-43410

DWG. NO. S13-2011
MITSUBISHI HEAVY INDUSTRIES, LTD.
GENERAL MACHINERY & SPECIAL VEHICLE HEADQUARTERS

CHECKED BY

T. HASHIGUCHI

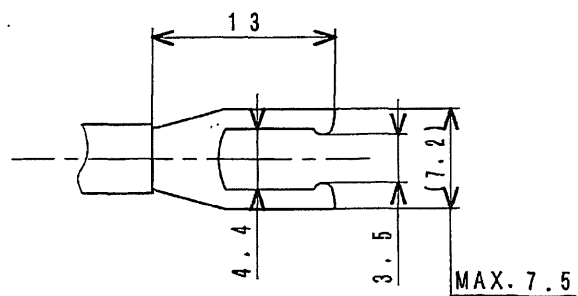
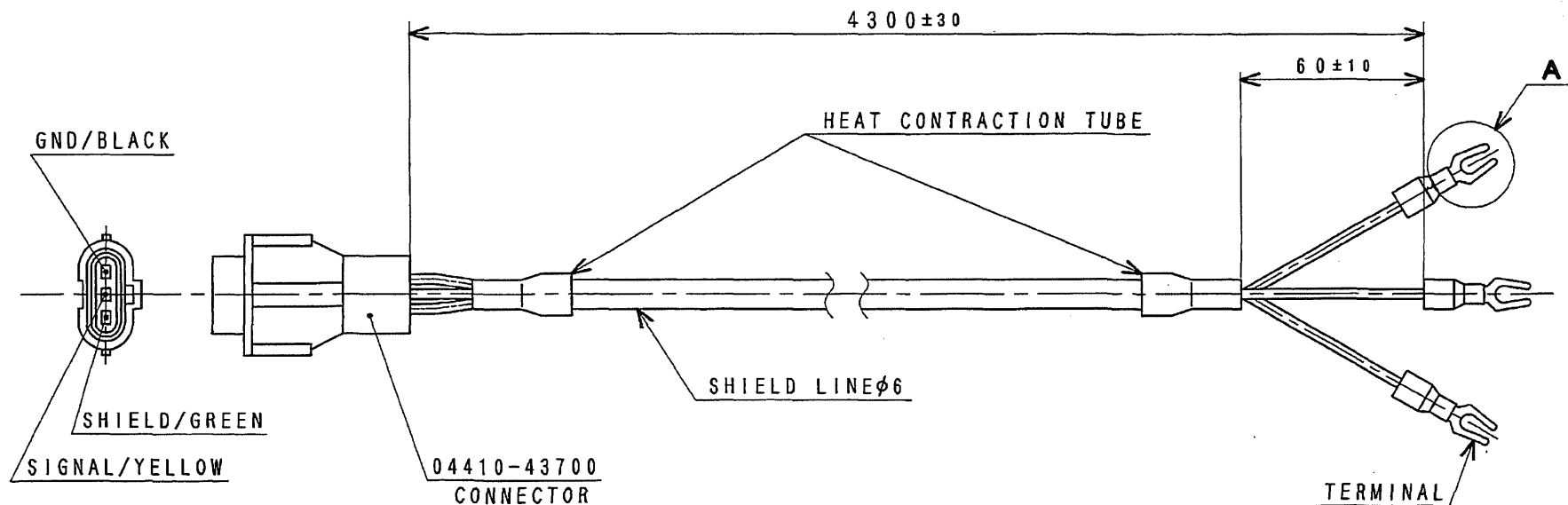

DETAIL A

MHI CONFIDENTIAL

△	
△	
1	'09.12.6
REV.	DATE

CABLE, PICKUP
PART NO. 04410-43500

DWG. NO. S13-2020

△ MITSUBISHI HEAVY INDUSTRIES, LTD.
GENERAL MACHINERY & SPECIAL VEHICLE HEADQUARTERS

CHECKED BY

Y. FUKUDA

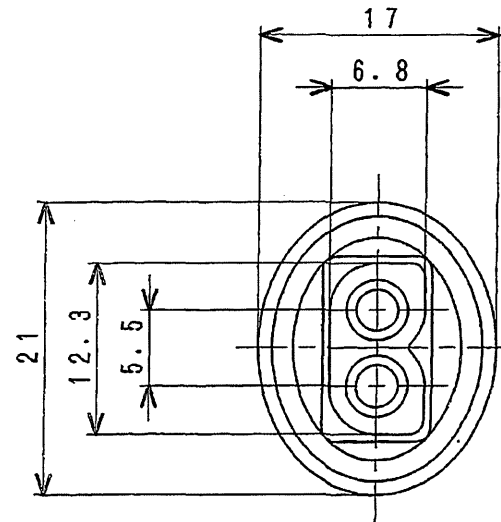
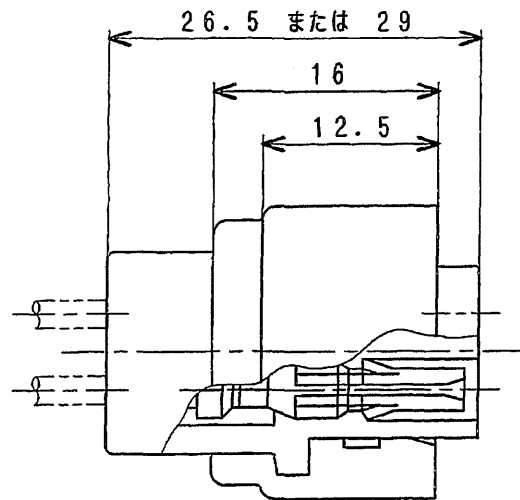

MHI CONFIDENTIAL

REV.	DATE
2	'04.3.12
1	'93.8.4

CONNECTOR
PART NO. MH052231

DWG. NO. S14-0330

MITSUBISHI HEAVY INDUSTRIES, LTD.
GENERAL MACHINERY & SPECIAL VEHICLE HEADQUARTERS

CHECKED BY

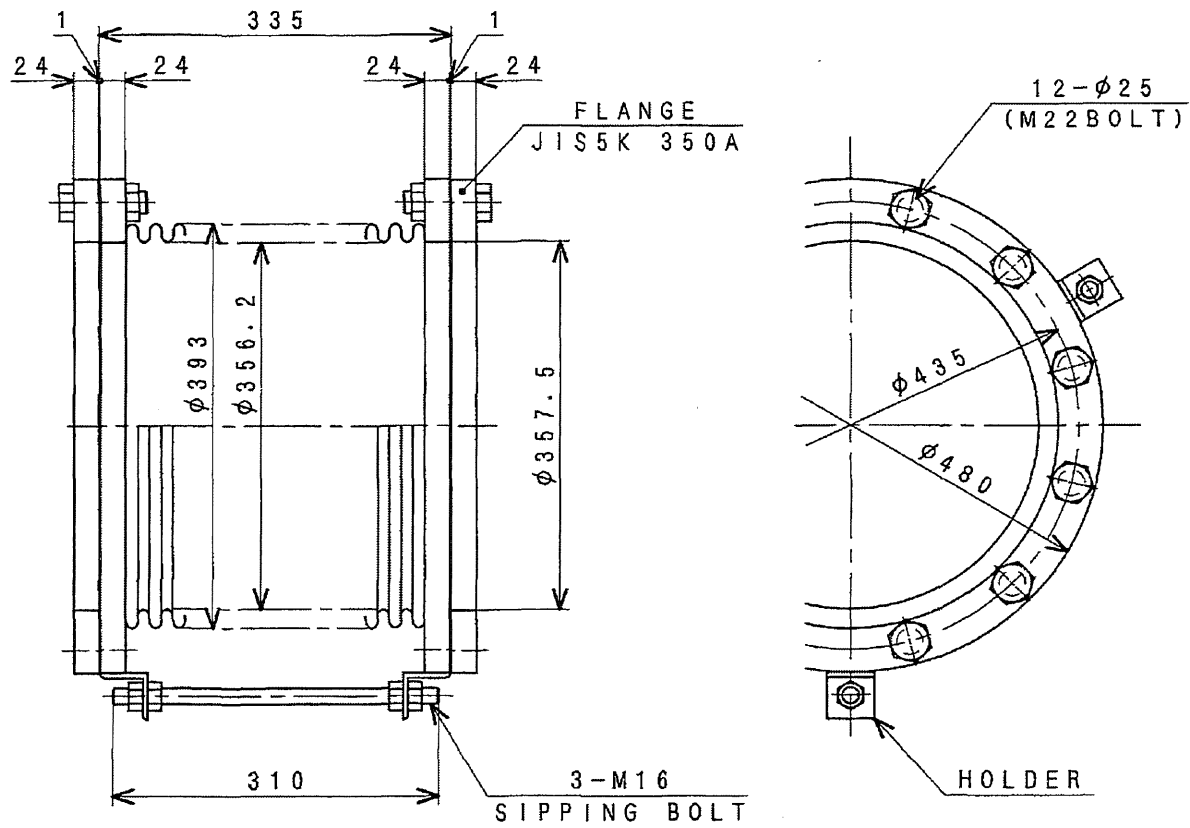

MHI CONFIDENTIAL

△	
△	
△	
REV.	DATE

PIPE, FLEXIBLE
PART NO. 47920-12400

DWG. NO. S37-1090

▲ MITSUBISHI HEAVY INDUSTRIES, LTD.

Same with 38G32-02400

CHECKED BY

Y. FUKUDA

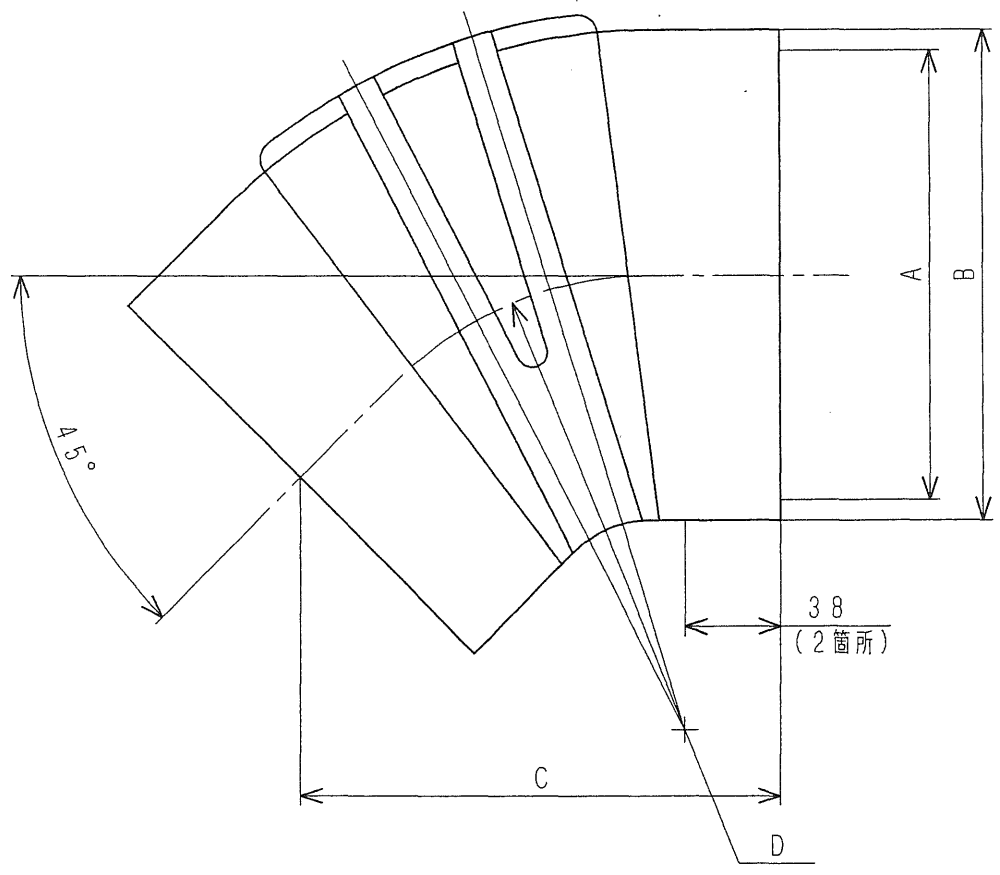

47220-31500	7" (ø177.8)	177.8	194.1	190.5	141.2
47220-31400	6" (ø152.4)	152.4	168.4	145.8	152.4
PARTS NO.	SIZE MEASURE	A	B	C	D

MHI CONFIDENTIAL

△	
△	
△	
REV.	DATE

ELBOW / 45°

DWG. NO. S35-0720

MITSUBISHI HEAVY INDUSTRIES, LTD.
SAGAMIHARA MACHINERY WORKS

CHECKED BY

T. HASHIGUCHI

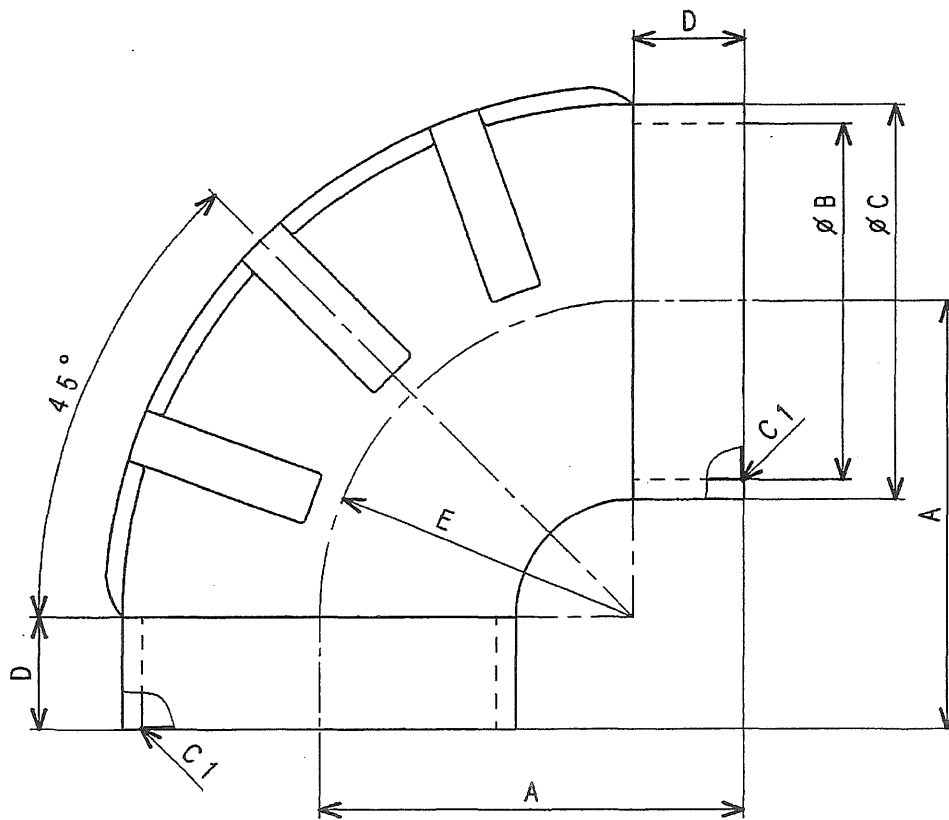

47220-47600	Ø160	145	160	176	40	100
47220-32600	7" (Ø177.8)	184.2	177.8	194.6	50.8	133.4
47220-30400	6" (Ø152.4)	177.8	152.4	166.4	50.8	127
47220-12100	5" (Ø127.0)	152.4	127	141	40	112.4
PARTS NO.	TYPE MEASURE	A	B	C	D	E

MHI CONFIDENTIAL

△	
△	
△	
REV.	DATE

HOSE, RUBBER

DWG. NO. S35-0701

MITSUBISHI HEAVY INDUSTRIES, LTD.
GENERAL MACHINERY & SPECIAL VEHICLE HEADQUARTERS

CHECKED BY

A. Fukuda

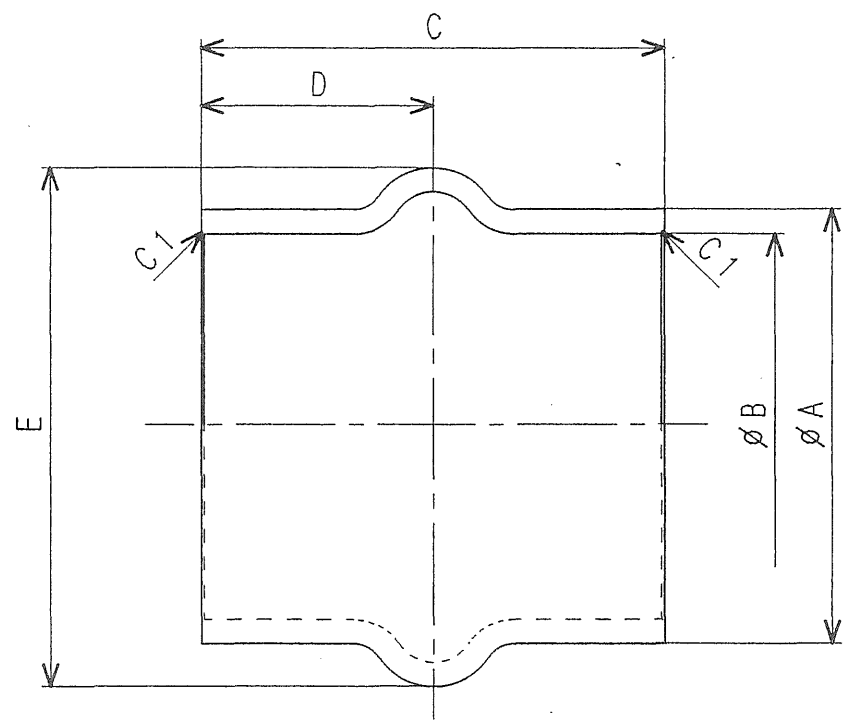

47220-47300	10" (ø254.0)	266.7	254	152.4	76.2	300
47220-31600	7" (ø177.8)	194	178	178	89	222
47220-30500	6" (ø152.4)	168.4	152.4	178	89	196.4
47220-13200	5" (ø127.0)	143	127	152.4	76.2	171
PARTS NO.	TYPE MEASURE	A	B	C	D	E

MHI CONFIDENTIAL

△	
△	
△	
REV.	DATE

HOSE, RUBBER

DWG. NO. S35-0711
 MITSUBISHI HEAVY INDUSTRIES, LTD.
 SAGAMIHARA MACHINERY WORKS

mitsubishi Diesel Engine TECHNICAL INFORMATION	ITEM NO.	T0233-0001E (1/4)
	DATE	April, 2016

Specification Sheets of S16R-PTA Engine

Specification Sheets of S16R-PTA Engine are enclosed herein.

Revision	First Edition : September, 2007 (T13-0311-E Jun.99)	Engine Engineering Department Engine System Designing Section		
		Approved by	Checked by	Drawn by
		T.HASHIGUCHI	T.HASEGAWA K.SAKAMOTO	N.Y

MITSUBISHI HEAVY INDUSTRIES, LTD.

GENERAL ENGINE DATA

Type	4-Cycle, Water Cooled	
Aspiration	Turbo-Charged, After Cooler (Jacket water to Cooler)	
Cylinder Arrangement	60°V	
No. of Cylinders	16	
Bore mm(in.)	170	(6.69)
Stroke mm(in.)	180	(7.09)
Displacement liter(in ³)	65.37	(3989)
Compression Ratio	14.0:1	
Dry Weight - Engine only - kg(lb)	6750	(14884)
Wet Weight - Engine only - kg(lb)	7127	(15715)

PERFORMANCE DATA

Steady State Speed Stability Band at any Constant Load

Electric Governor - %	±0.25 or better	
Maximum Overspeed Capacity - rpm	2100	
Moment of inertia of Rotating Components - N·m ² (lbf·ft ²)	793	(1918)
(Includes Std. Flywheel)		
Cyclic Speed Variation with Flywheel at 1800rpm	1/283	
1500rpm	1/188	
1200rpm	1/131	

ENGINE MOUNTING

Maximum Bending Moment at Rear Face of Flywheel Housing - N·m(lbf·ft)	4413	(3256)
---	------	--------

AIR INLET SYSTEM

Maximum Intake Air Restriction (Includes piping)

With Clean Filter Element - mm H ₂ O (in. H ₂ O)	400	(15.7)
With Dirty Filter Element - mm H ₂ O (in. H ₂ O)	635	(25.0)

EXHAUST SYSTEM

Maximum Allowable Back Pressure - mm H ₂ O (in. H ₂ O)	600	(23.6)
--	-----	--------

LUBRICATION SYSTEM

Oil Pressure at Idle - MPa(psi)	0.2~0.3	(29~43)
at Rate Speed - MPa(psi)	0.49~0.64	(71~93)
Maximum Oil Temperature of Oil pan - °C(°F)	110	(230)
Oil Capacity of Standard Oil pan High - liter (U.S. gal)	200	(52.8)
Low - liter (U.S. gal)	140	(37.0)
Total System Capacity (Includes Oil Filter) - liter (U.S. gal)	230	(60.8)
Maximum Angle of Installation (Std. Pan) Front Down	5°	
(Engine Only) Front Up	5°	
Side to Side	22.5°	

COOLING SYSTEM

Coolant Capacity (Engine only) - liter (U.S. gal)	170	(44.9)
Maximum External Friction Head at Engine Outlet - MPa(psi)	0.034	(5.0)
Maximum Static Head of Coolant above Crankshaft Center - m(ft)	10	(32.8)
Maximum Outlet Pressure of Engine Water Pump - MPa(psi)	0.20	(28.6)
Standard Thermostat (modulating) Range- °C(°F)	71~85	(160~185)
Maximum Coolant Temperature at Engine Outlet- °C(°F)	98	(208)
Minimum Coolant Expansion Space - % of System Capacity	10	
Maximum Coolant Temperature at Intercooler Inlet, TK type- °C(°F)	-	
Maximum Air Restriction on Discharge Side of Radiator and Fan-mm H ₂ O(in. H ₂ O)	10	(0.4)

The specifications are subject to change without notice.

APPLICATION : GENERATOR

Pub. No. T0233-0001E 2/4

FUEL SYSTEM

Fuel Injector	Mitsubishi PS8 × 2
Maximum Suction Head of Feed Pump - mm Hg (in. Hg)	75 (3.0)
Maximum Static Head of Return & Leak Pipe - mm Hg (in.Hg)	150 (5.9)

STARTING SYSTEM

Battery Charging Alternator - V-Ah	24-30
Starting Motor Capacity - V -kW	24-7.5×2
Maximum Allowable Resistance of Cranking Circuit - m Ω	1.5
Recommended Minimum Battery Capacity	
At 5 °C(41°F) and above - Ah	300
Below 5 °C(41°F) through - 5 °C(23°F)	600

The specifications are subject to change without notice.

APPLICATION : GENERATOR

Pub. No. T0233-0001E 3/4

S16R-PTA

SPECIFICATION SHEET

MITSUBISHI
DIESEL ENGINES

ENGINE RATING

All data represent net performance with standard accessories such as air cleaner, inlet /exhaust manifolds, fuel oil system, L.O. pump, etc. under the condition of 100kPa(29.6inHg) barometric pressure, 77°F(25°C) ambient temperature and 30% relative humidity.

ITEM	UNIT	STAND-BY POWER			PRIME POWER			CONTINUOUS C	CONTINUOUS D
		60Hz	50Hz	60Hz	60Hz	50Hz	60Hz	50Hz	50Hz
Engine Speed	rpm	1800	1500	1200	1800	1500	1200	1500	1500
No. of Cylinders		16							
Bore	mm (in.)	170 (6.69)							
Stroke	mm (in.)	180 (7.09)							
Displacement	liter (in. ³)	65.37 (3989)							
Brake Horse power without Fan	kW (HP)	1750 (2346)	1620 (2172)	1120 (1501)	1590 (2131)	1480 (1984)	1020 (1367)	1330 (1783)	1180 (1582)
Brake Mean Effective Pressure without Fan	MPa (psi)	1.8 (258)	2.0 (287)	1.7 (248)	1.6 (235)	1.8 (262)	1.6 (226)	1.6 (236)	1.4 (209)
Mean Piston Speed	m/s (ft/min)	10.8 (2126)	9.0 (1772)	7.2 (1417)	10.8 (2126)	9.0 (1772)	7.2 (1417)	9.0 (1772)	9.0 (1772)
Maximum Regenerative Power Absorption Capacity without Fan	kW (HP)	192 (258)	140 (188)	96 (129)	192 (258)	140 (188)	96 (129)	140 (188)	140 (188)
Intake Air flow	m ³ /min (CFM)	141 (4979)	128 (4520)	90 (3178)	127 (4484)	117 (4131)	82 (2895)	107 (3778)	96 (3390)
Exhaust Gas Flow	m ³ /min (CFM)	373 (13171)	339 (11970)	237 (8368)	337 (11899)	309 (10911)	216 (7627)	284 (10028)	253 (8933)
Coolant Flow	liter/min (U.S. GPM)	1850 (489)	1650 (436)	1300 (343)	1850 (489)	1650 (436)	1300 (343)	1650 (436)	1650 (436)
Coolant Flow to Intercooler (TK only)	liter/min (U.S. GPM)	—	—	—	—	—	—	—	—
Cooling Air Flow (Std. Fan)	m ³ /min (CFM)	1950 (68855)	1950 (68855)	1560 (55084)	1950 (68855)	1950 (68855)	1560 (55084)	1950 (68855)	1950 (68855)
Fan Loss Horse Power (Std. Fan)	kW (HP)	50 (67)	30 (40)	20 (27)	50 (67)	30 (40)	20 (27)	30 (40)	30 (40)
Radiated Heat to Ambient	kJ/hr (BTU/min)	444750 (7027)	403417 (6374)	282634 (4466)	401261 (6340)	368498 (5822)	257402 (4067)	338017 (5341)	301939 (4771)
Heat Rejection to Coolant	kJ/hr (BTU/min)	3706247 (58558)	3361804 (53116)	2355280 (37213)	3343839 (52832)	3070819 (48518)	2145016 (33891)	2816811 (44505)	2516155 (39755)
Heat Rejection to Inter Cooler (TK Version)	kJ/hr (BTU/min)	—	—	—	—	—	—	—	—
Heat Rejection to Exhaust	kJ/hr (BTU/min)	4374807 (69121)	3850015 (60829)	2752910 (43495)	3908364 (61751)	3516772 (55564)	2507147 (39612)	3324929 (52533)	2998740 (47379)
Noise Level (1 m height & distance) (excludes, Intake, Exhaust & Fan)	dB(A)	TBD	TBD	TBD	TBD	TBD	TBD	TBD	TBD

The specifications are subject to change without notice.

APPLICATION : GENERATOR

Pub. No. T0233-0001E 4/4